

1	Type	Line Scan lens
2	Resolution	4K/7 μ m
3	Image Format	/
4	Image Circle	ϕ 30.00mm(MAX)
5	EFL	12mm
6	F/NO.	F2.0-22
7	FFL (M)	/
8	BFL (O)	/
9	For Sensor	/
10	F.O.V	97°
11	Distortion	<1.5%
12	M.O.D	0.2m~ ∞
13	Mount Type	M42*P1.0
14	Dimension Figure	ϕ 67.00*L59.3mm
15	Lens Structure	/
16	Filter Size	62MM
17	Weight	263g

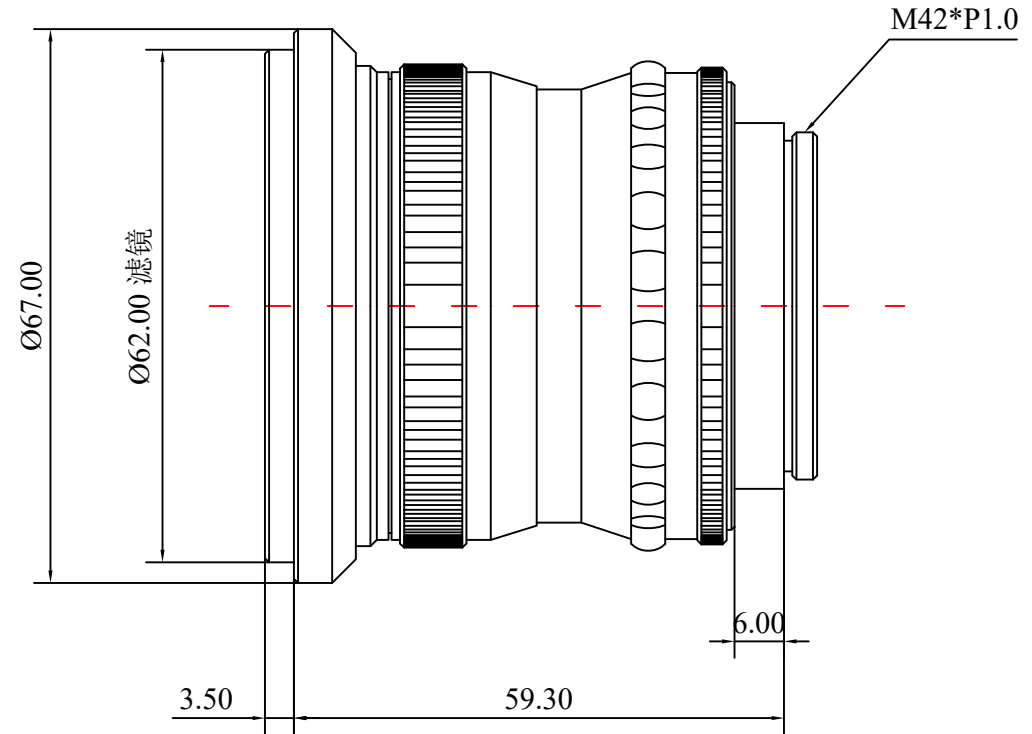
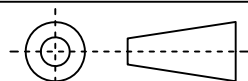

18	Iris Operation	Manual	Scale	Remark	Tolerances	Date	Revised		福州创安光电科技有限公司 FUZHOU CHUANGAN OPTICS CO., LTD
19	Zoom Operation	Fixed		4:1	X	± 0.2	2024-11-05	CH8098A Rev1.0	
20	Focus Operation	Manual	Units	X.0	± 0.15	Design	Linda	2023-03-14	
21	Operating Temperature	-20° ~+85°	mm	X.000	± 0.001	Checked	Anna	2023-04-26	 3D Angle Projection
22	Storage Temperature	-20° ~+85°		Angle	$\pm 0.5^\circ$	Approval	Sanmu	2023-06-15	