

1	Type	M6 Lens	
2	Resolution	5MP	
3	Image Format	1/2.8"	
4	Image Circle	φ6.8mm(MAX)	
5	EFL	2.65mm	
6	TTL	5.7mm	
7	F/NO.	F2.4	
8	FFL (M)	0.80mm	
9	BFL (O)	1.02mm	
10	For Sensor	1/2.8"	
11	F.O.V	Horizontal	100°
12		Vertical	76.4°
13		Diagonal	125.1°
14	TV Distortion	<-15%	
15	Relative Ill.	>27.6%	
16	Chief Ray Angle	<37°	
17	M.O.D	0.1m~∞	
18	Mount Type	M6.8*P0.25	
19	Dimension Figure	φ7.5*L4.9mm	
20	Lens Structure	6P	
21	IR-Filter	Non-IR	
22	Waterproof	No	
23	Weight	---	
24	Iris Operation	Fixed	
25	Zoom Operation	Fixed	
26	Focus Operation	Manual	
27	Operating Temperature	-15° ~+45°	
28	Storage Temperature	-15° ~+45°	

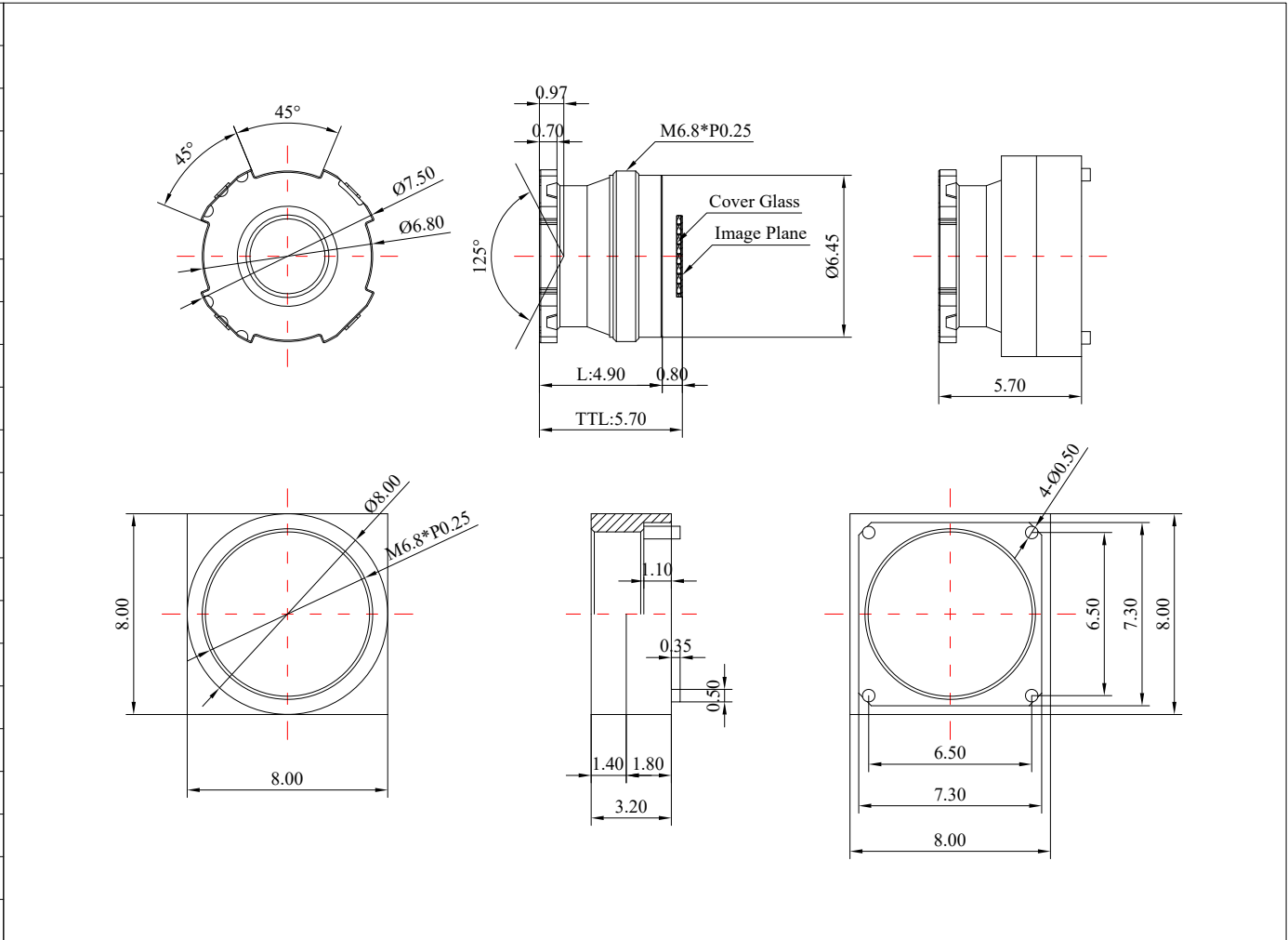
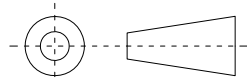

Scale	Remark	Tolerances	Date	Revised		福州创安光电科技有限公司 FUZHOU CHUANGAN OPTICS CO., LTD
4:1	X	±0.2	2024-03-18	CH8075A Rev1.0		
Units	X.00	±0.10	Design	Linda	2024-02-27	 3D Angle Projection
	X.000	±0.001	Checked	Anna	2024-03-11	
mm	Angle	±0.5°	Approval	Sanmu	2024-03-17	