

1	Type	ToF Lens	
2	Resolution	MP	
3	Image Format	1/2"	
4	Image Circle	φ8.4mm(MAX)	
5	EFL	5.3mm	
6	TTL	16.80mm	
7	F/NO.	1.3	
8	FFL (M)	3.50mm	
9	BFL (O)	3.65mm	
10	For Sensor	EPC660	
11	F.O.V	Horizontal	75°
12		Vertical	55°
13		Diagonal	95°
14	OPT Distortion	<-30%	
15	Relative Ill.	>76%	
16	Chief Ray Angle	<20°	
17	M.O.D	0.3m~∞	
18	Mount Type	M12*P0.5	
19	Dimension Figure	φ14.00*L13.30mm	
20	Lens Structure	6G	
21	IR-Filter	Non-IR	
22	Waterproof	No	
23	Weight	---	
24	Iris Operation	Fixed	
25	Zoom Operation	Fixed	
26	Focus Operation	Manual	
27	Operating Temperature	-25° ~+85°	
28	Storage Temperature	-25° ~+85°	

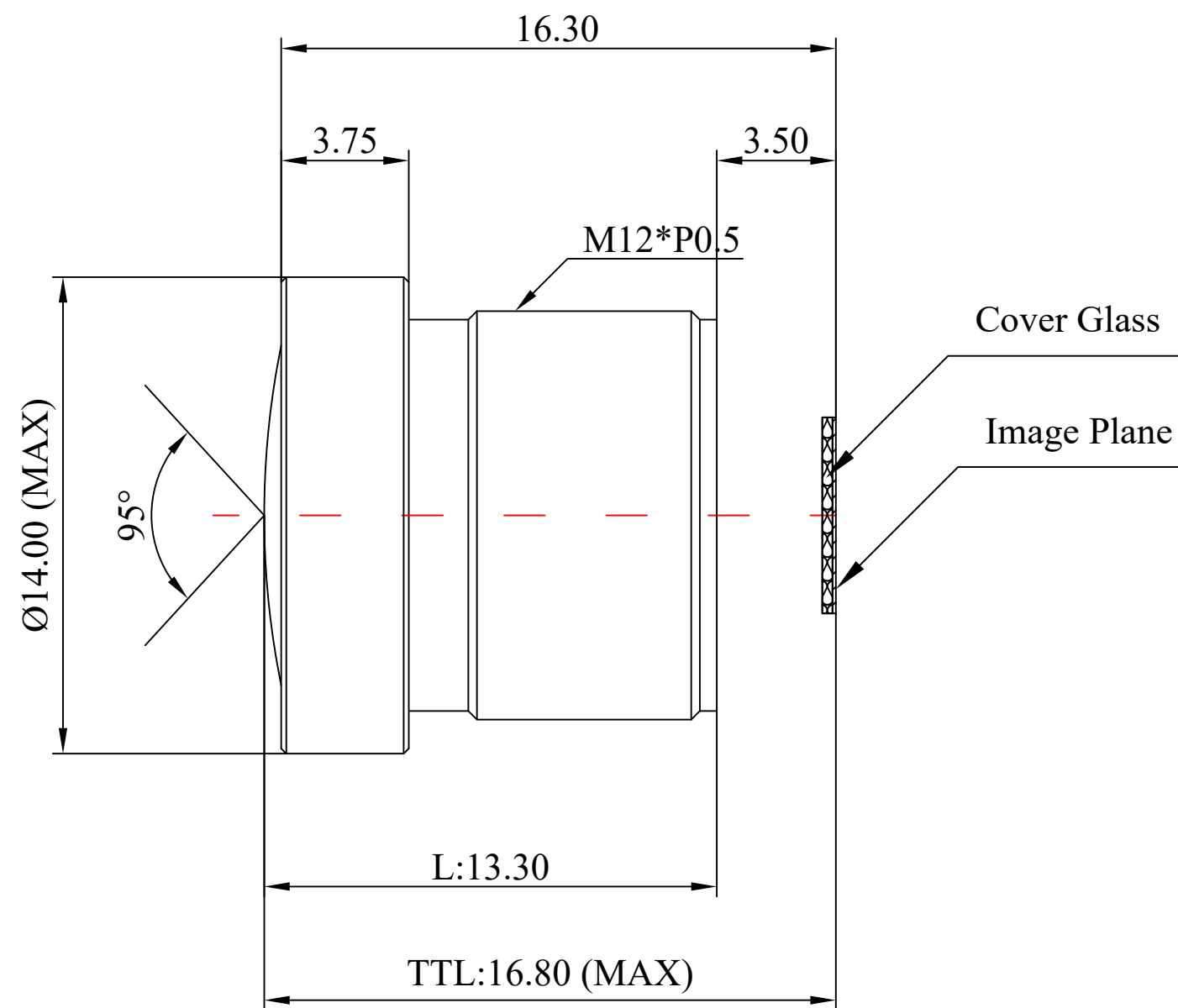

Scale	Remark	Tolerances	Date	Revised		福州创安光电科技有限公司 FUZHOU CHUANGAN OPTICS CO., LTD
4:1	X	±0.2	2022-12-19	CH8048A Rev1.0		
	X.0	±0.15				
Units	X.00	±0.10	Design	Linda	2022-12-01	
	X.000	±0.001	Checked	Anna	2022-12-07	
mm	Angle	±0.5°	Approval	Sanmu	2021-12-17	

