

1	Type	Wide Angle Lens	
2	Resolution	5MP	
3	Image Format	1/3.2"	
4	Image Circle	φ5.8mm(MAX)	
5	EFL	2.05mm	
6	TTL	13.99mm	
7	F/NO.	2.0	
8	FFL (M)	3.52mm	
9	BFL (O)	3.65mm	
10	For Sensor	ISX-017	
11	F.O.V	Horizontal	128°
12		Vertical	93°
13		Diagonal	170°(MAX)
14	TV Distortion	<-45%	
15	Relative Ill.	>70%	
16	Chief Ray Angle	<12.8°	
17	M.O.D	0.1m~∞	
18	Mount Type	M12*P0.5	
19	Dimension Figure	φ12.00*L10.47mm	
20	Lens Structure	5G All Glass	

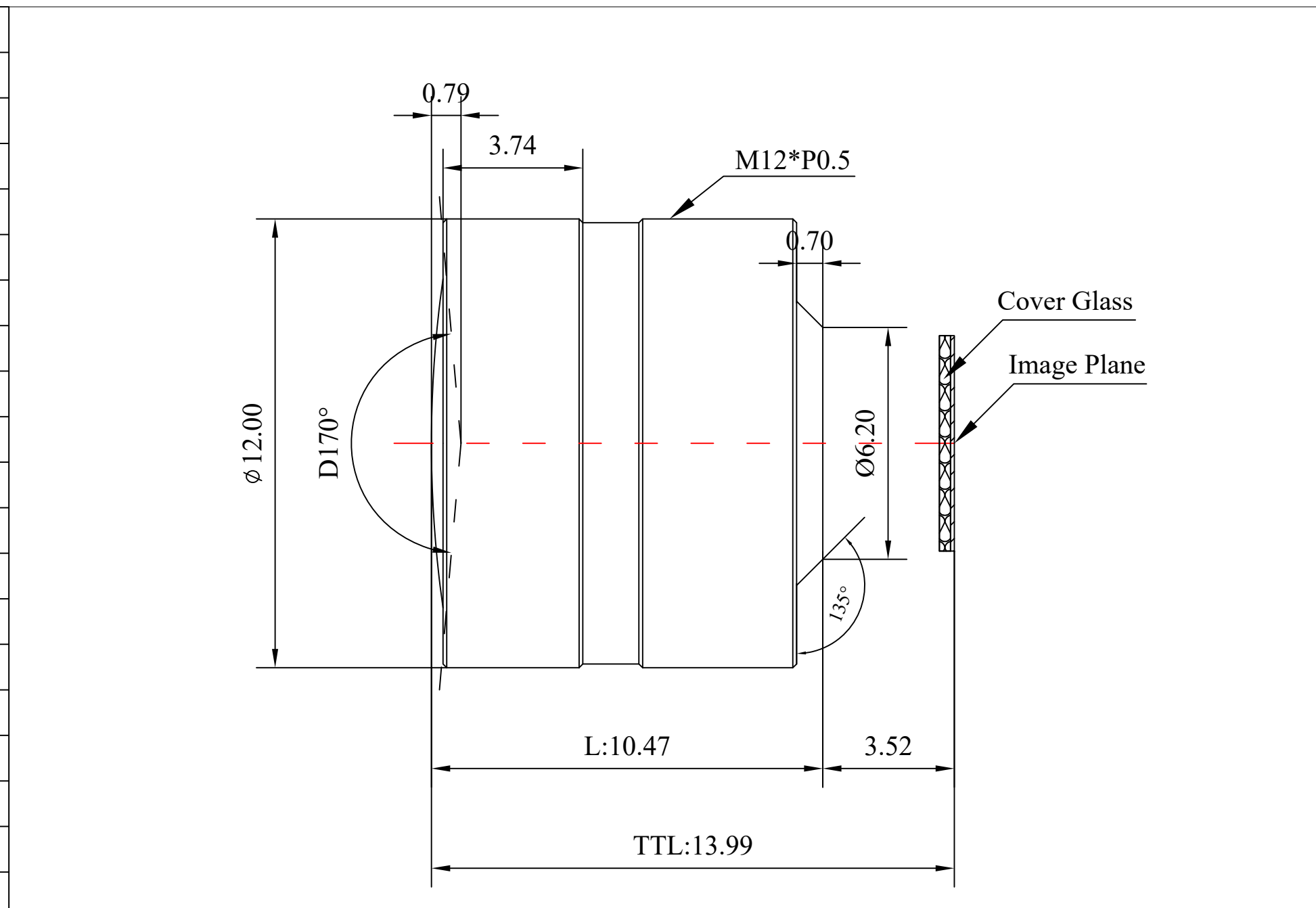
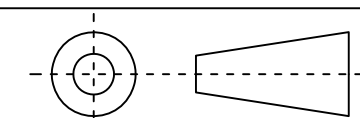

Remark: 多层镀膜G1黑色涂墨

21	IR-Filter	Non-IR						
22	Weight	2.0g	Scale	Remark	Tolerances	Date	Revised	
23	Iris Operation	Fixed		X	± 0.2	2021-01-05	CH8025AG Rev1.1	
24	Zoom Operation	Fixed		5: 1	X.0	± 0.15		
25	Focus Operation	Manual	Units	X.00	± 0.10	Design	Linda	2018-08-10
26	Operating Temperature	-20° ~+85°		X.000	± 0.001	Checked	Anna	2018-08-20
27	Storage Temperature	-20° ~+85°	mm	Angle	± 0.5°	Approval	Sanmu	2018-08-31

 福州创安光电科技有限公司
 FUZHOU CHUANGAN OPTICS CO., LTD

3D Angle Projection