

1	Type	Machine vision Lens	
2	EFL	100mm	
3	F.NO	F3.5~32	
4	Resolution	8MP	
5	Image Format	1"	
6	BFL (M)	17.53	
7	For Sensor	1"	2/3"
8	F.O.V	Horizontal	7.2°
9		Vertical	5.5°
10		Diagonal	9.7°
11	TV Distortion	<-0.03%	<-0.025%
12	M.O.D	1.5m	
13	Mount Type	C/CS	
14	Dimension Figure	φ42.0*L58.5	
15	Filter Size	M40.5*0.5	
16	Weight	160g	
17	Iris Operation	Manual	
18	Zoom Operation	Fixed	
19	Focus Operation	Manual	
20	Operating Temperature	-20° +85°	
21	Storage Temperature	-20° +85°	

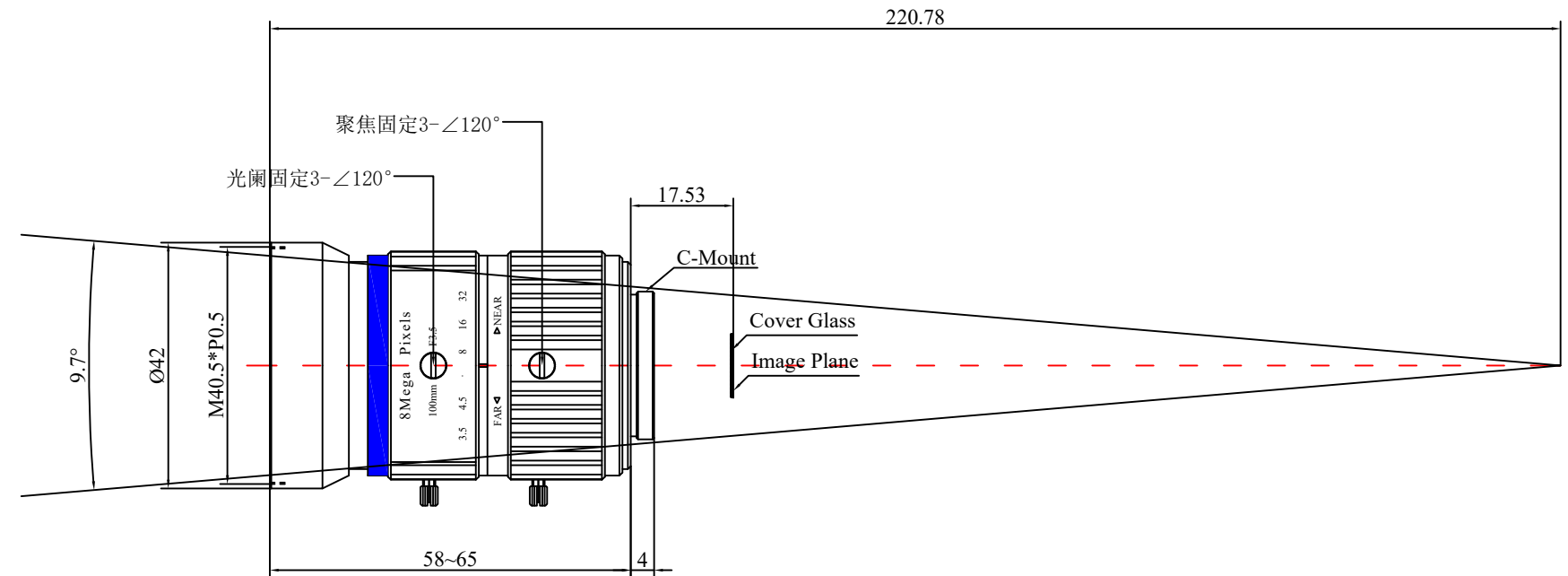

Scale	Remark	Tolerances	Date	Revised		福州创安光电科技有限公司 FUZHOU CHUANGAN OPTICS CO., LTD
1.5 : 1	X	± 0.2	2023-08-25	CH615A Rev1.1		
	X.0	± 0.15				
Units	X.00	± 0.10	Design	Linda	2016-02-10	
	X.000	± 0.001	Checked	Anna	2016-05-07	
mm	Angle	± 0.5°	Approval	Sanmu	2016-05-28	

