

1	Type	Machine vision Lens	
2	EFL	75mm	
3	F.NO	F2.8~16	
4	Resolution	10MP	
5	Image Format	1"	
6	BFL (M)	17.53	
7	For Sensor	1"	2/3"
8	F.O.V	Horizontal	9.8°
9		Vertical	7.4°
10		Diagonal	12.2°
11	TV Distortion	<-0.05%	<-0.03%
12	M.O.D	0.1m	
13	Mount Type	C/CS	
14	Dimension Figure	φ39.0*L46	
15	Filter Size	M35.5*0.5	
16	Weight	120g	

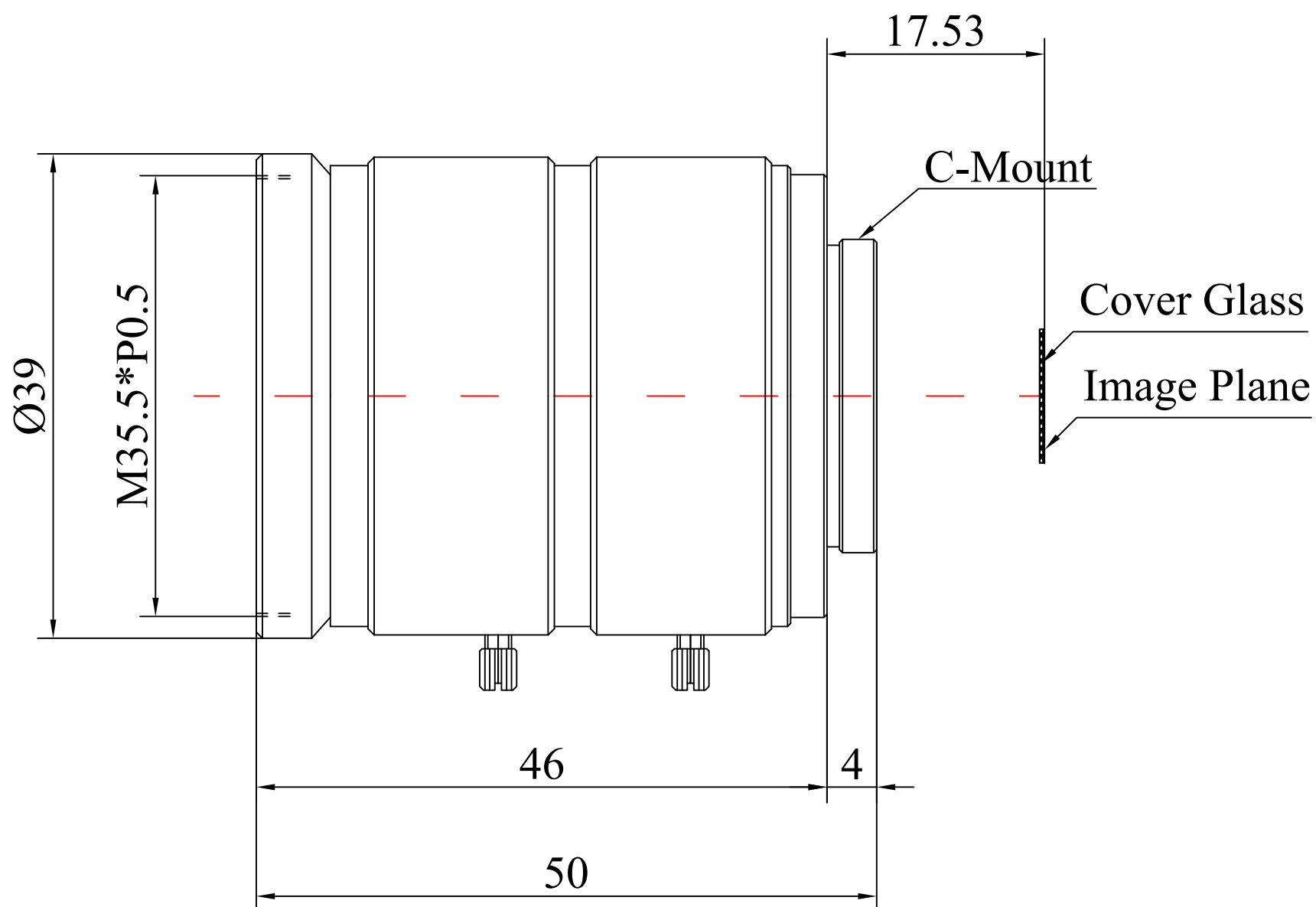
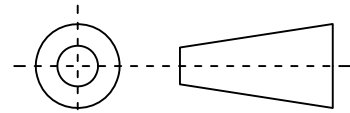

		Scale	Remark	Tolerances	Date	Revised		福州创安光电科技有限公司 FUZHOU CHUANGAN OPTICS CO., LTD
17	Iris Operation	Manual	X	±0.2	2021-01-15	CH614A Rev1.0		
18	Zoom Operation	Fixed	X.0	±0.15				
19	Focus Operation	Manual	X.00	±0.10	Design	Linda	2016-02-10	 3D Angle Projection
20	Operating Temperature	-20° +85°	X.000	±0.001	Checked	Anna	2016-05-07	
21	Storage Temperature	-20° +85°	Angle	±0.5°	Approval	Sanmu	2016-05-28	