

1	Type	Machine vision
2	EFL	50mm
3	F.NO	1.4~16
4	Resolution	8MP
5	Image Format	1"
6	FFL (M)	13.53
7	BFL (O)	17.53
8	F.O.V (H*V)	1" 13.9°*10.4°
9		2/3" 9.6°*7.1°
10		1/2" 6.96°*5.3°
11	TV Distortion	<1.0%
12	M.O.D	0.1m~∞
13	Mount Type	C/CS
14	Dimension Figure	φ39.0*L56.0mm
15	Filter Size	No
16	Weight	134g

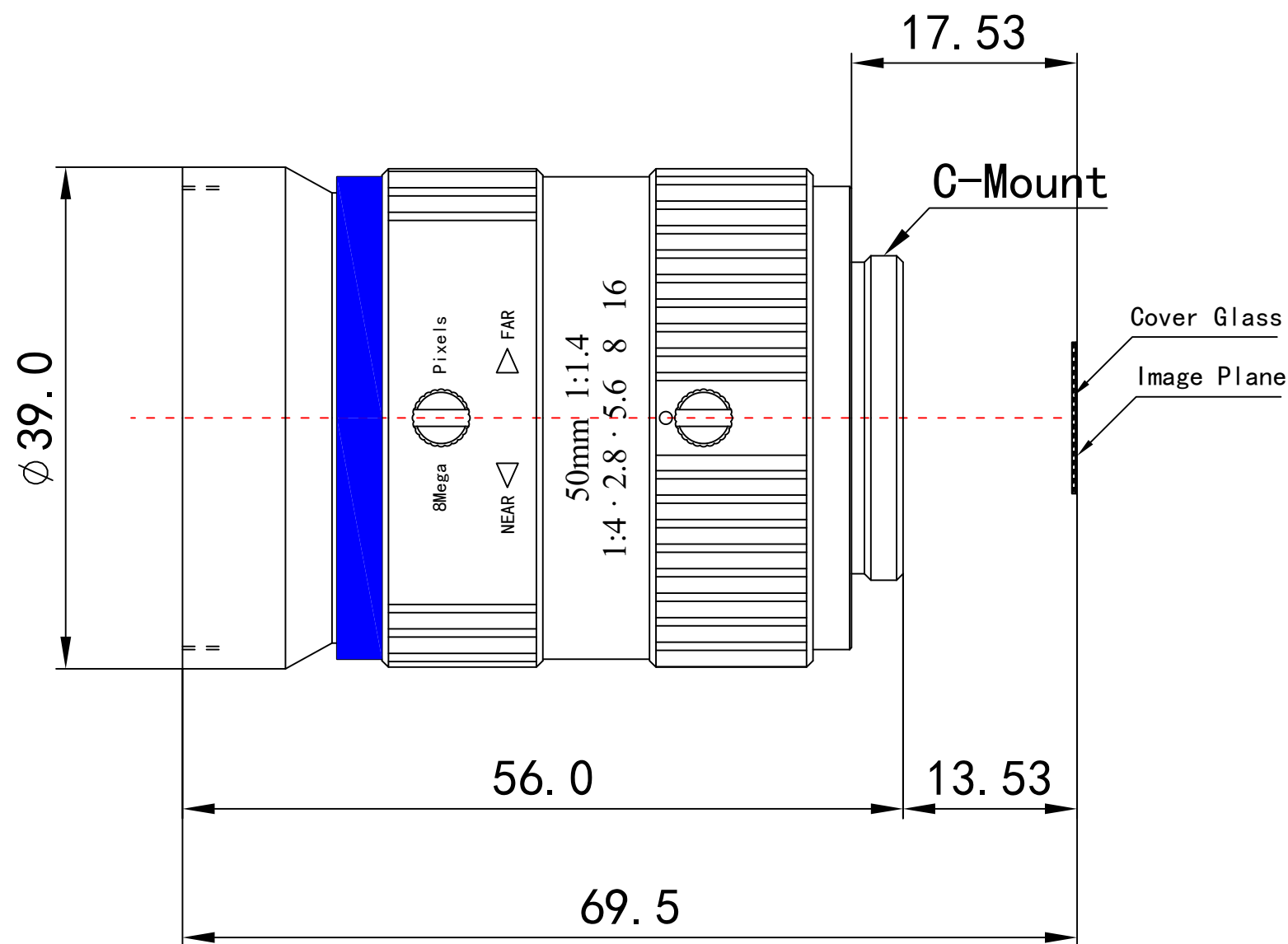
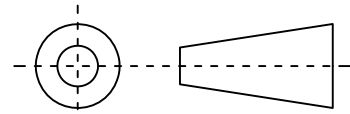

17	Iris Operation	Manual	Scale	Remark	Tolerances	Date	Revsied		福州创安光电科技有限公司 FUZHOU CHUANGAN OPTICS CO., LTD  3D Angle Projection
18	Zoom Operation	Fixed		X	±0.2	2021-01-14	CH613A Rev1.1		
19	Focus Operation	Manual	1.5: 1	X.0	±0.15				
20	Operating Temperature	-20° +85°	Units	X.00	±0.10	Design	Linda	2012-03-07	
21	Storage Temperature	-20° +85°		X.000	±0.001	Checked	Anna	2012-03-28	
			mm	Angle	±0.5°	Approval	Sanmu	2012-05-16	