

1	Type	Machine vision Lens	
2	EFL	16mm	
3	F.NO	F1.4~16	
4	Resolution	10MP	
5	Image Format	1"	
6	BFL (M)	17.53	
7	For Sensor	1"	2/3"
8	F.O.V	Horizontal	43.6°
9		Vertical	33.4°
10		Diagonal	53.1°
11	TV Distortion	<-0.5%	<-0.3%
12	M.O.D	0.2m	
13	Mount Type	C/CS	
14	Dimension Figure	φ39.0*L56	
15	Filter Size	M37*0.75	
16	Weight	137g	

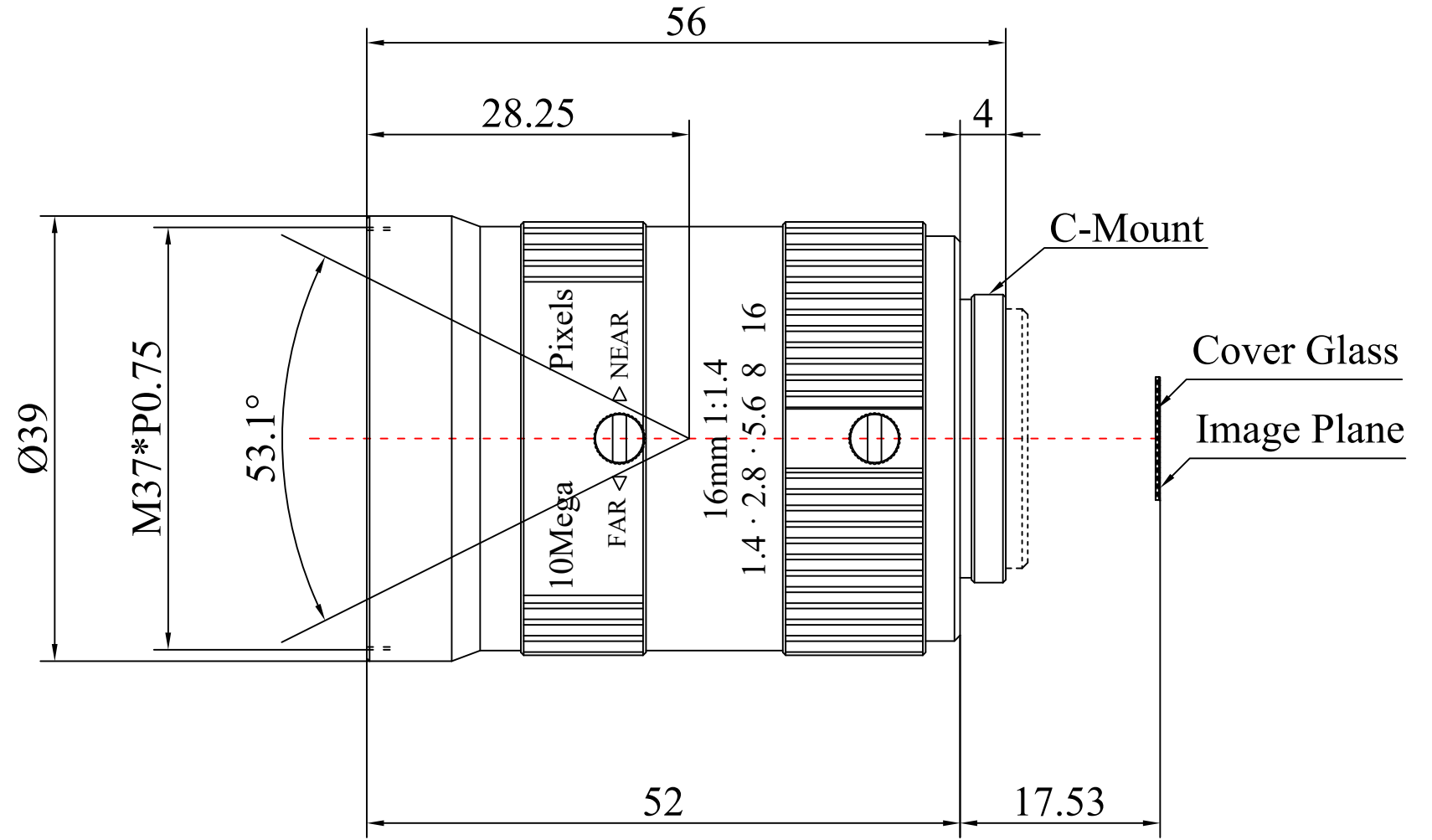
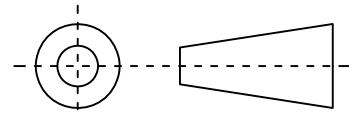

		Scale	Remark	Tolerances	Date	Revised		福州创安光电科技有限公司 FUZHOU CHUANGAN OPTICS CO., LTD
17	Iris Operation	Manual	X	±0.2	2023-05-09	CH610A Rev1.1		
18	Zoom Operation	Fixed	X.0	±0.15				
19	Focus Operation	Manual	X.00	±0.10	Design	Linda	2016-02-10	 3D Angle Projection
20	Operating Temperature	-20° +85°	X.000	±0.001	Checked	Anna	2016-05-07	
21	Storage Temperature	-20° +85°	mm	Angle	Approval	Sanmu	2016-05-28	