

1	Type	Machine vision Lens			
2	EFL	50mm			
3	F.NO	F2.8~22			
4	Resolution	20MP			
5	Image Format	1.1"			
6	BFL (M)	17.53			
7	For Sensor	1.1"	1"	2/3"	
8	F.O.V	Horizontal	15.9°	14.6°	10.1°
9		Vertical	11.9°	10.9°	7.5°
10		Diagonal	19.9°	18.2°	12.6°
11	TV Distortion	<0.05%	<0.05%	<0.03%	
12	M.O.D	0.1m			
13	Mount Type	C/CS			
14	Dimension Figure	φ38.00*L57.9			
15	Filter Size	M35.5*P0.5			
16	Weight	---			

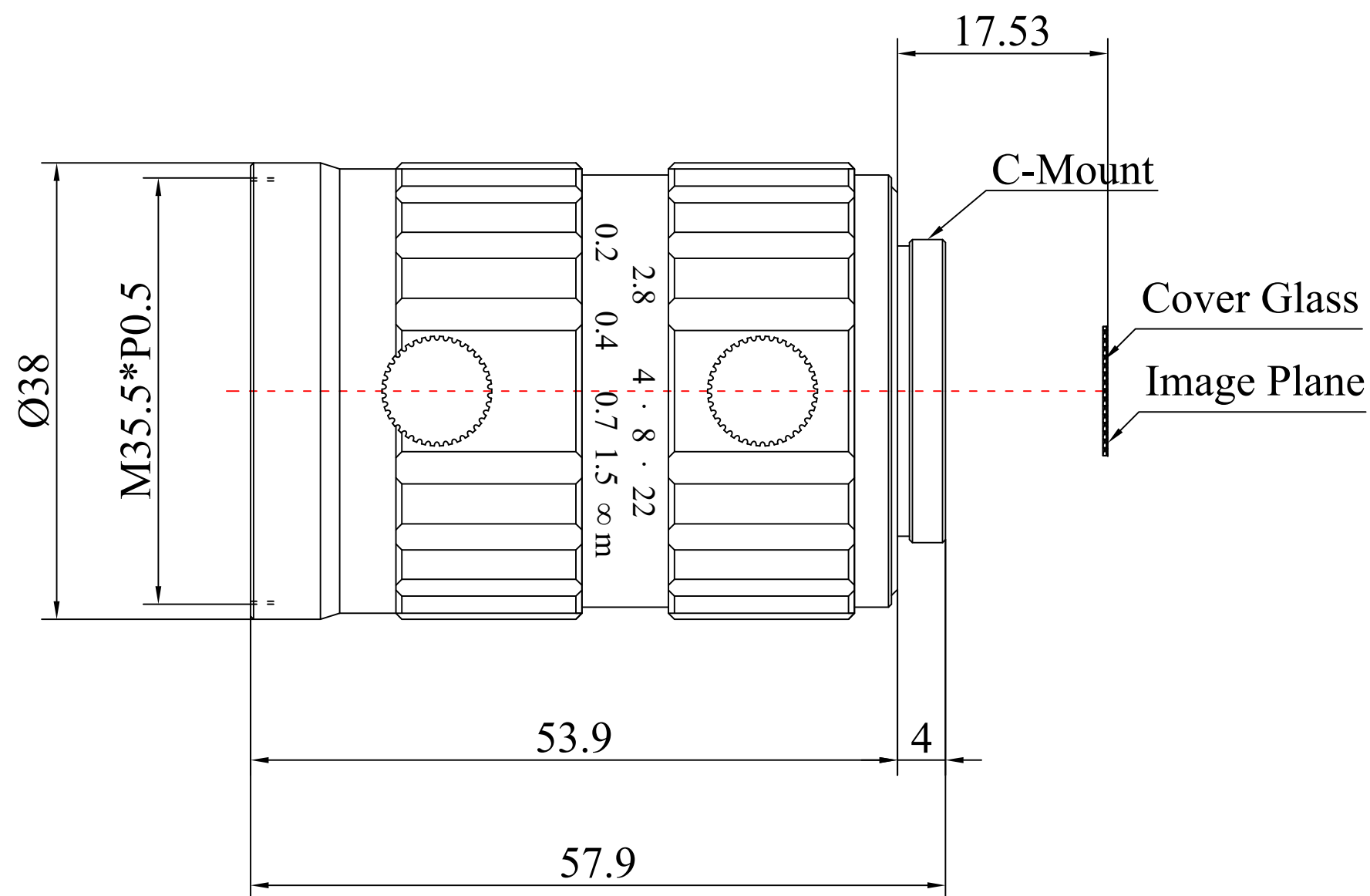

	Iris Operation	Manual	Scale	Remark	Tolerances	Date	Revised		福州创安光电科技有限公司 FUZHOU CHUANGAN OPTICS CO., LTD
							CH606A Rev1.0		
18	Zoom Operation	Fixed	1.5 : 1	X	±0.2	2021-01-15			
19	Focus Operation	Manual		X.0	±0.15				
20	Operating Temperature	-20° +85°	Units	X.00	±0.10	Design	Linda	2016-02-10	
				X.000	±0.001	Checked	Anna	2016-05-07	
21	Storage Temperature	-20° +85°	mm	Angle	±0.5°	Approval	Sanmu	2016-05-28	

