

穴号标记处: 凸出0.2mm以下

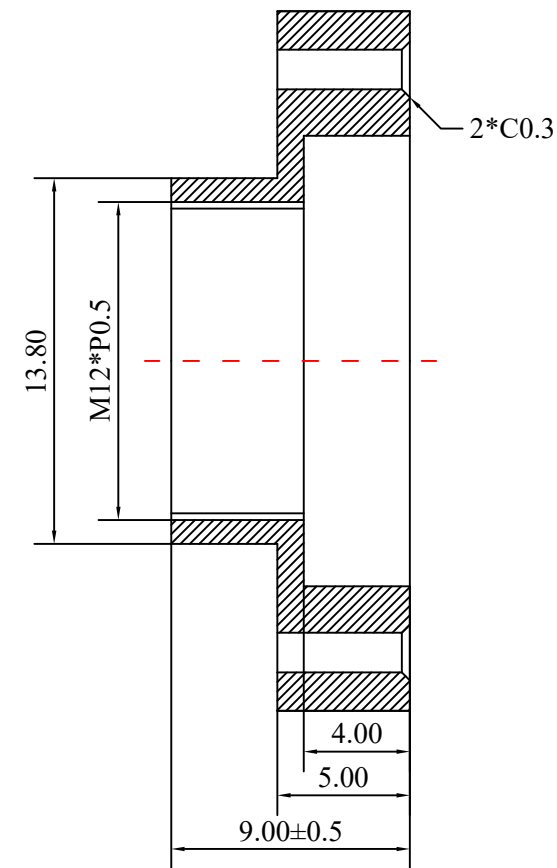

1	Product No.	CH5008A	Scale	Remark	Tolerances	Date	Revised	
2	Material Type	PA					X	± 0.2
3	Operating Temperature	-20° ~ +85°	2.5 : 1	X.0	± 0.15			
4	Storage Temperature	-20° ~ +85°	Units	X.00	± 0.10	Design	Linda	2015-06-23
5	Adaptable Products	---		X.000	± 0.001	Checked	Anna	2015-09-12
6		---	mm	Angle	± 0.5°	Approval	Sanmu	2015-10-10

福州创安光电科技有限公司
FUZHOU CHUANGAN OPTICS CO., LTD

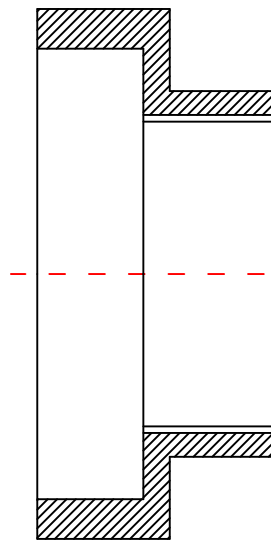
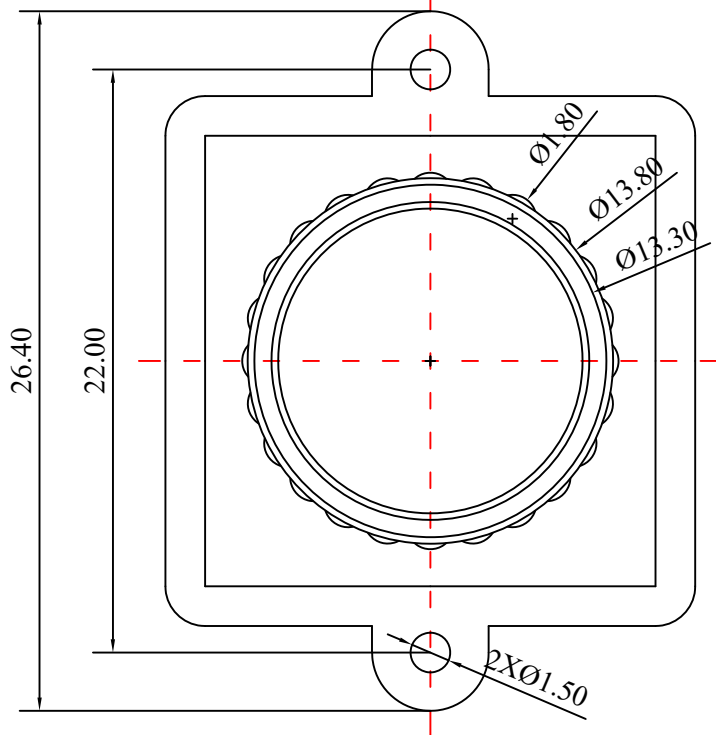
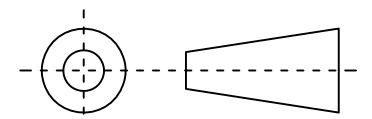

3D Angle Projection