

1	Type	Non Distortion Lens	
2	Resolution	5MP	
3	Image Format	1/2.7"	
4	Image Circle	φ6.8mm(MAX)	
5	EFL	4.57mm	
6	TTL	7.80mm	
7	F/NO.	2.5	
8	FFL (M)	0.90mm	
9	BFL (O)	1.45mm	
10	For Sensor	IMX335	OV2710
11	F.O.V	Horizontal	62° 65°
12		Vertical	36° 39°
13		Diagonal	70° 73°
14	OPT Distortion	<-1.0%	
15	Relative Ill.	>50%	
16	Chief Ray Angle	<16.7°	
17	M.O.D	0.1m~∞	
18	Mount Type	M8*P0.35	
19	Dimension Figure	φ8.0*L6.90mm	
20	Lens Structure	1G3P	
21	IR-Filter	T=50% & 650±10nm	
22	Waterproof	No	
23	Weight	1.0g	
24	Iris Operation	Fixed	
25	Zoom Operation	Fixed	
26	Focus Operation	Manual	
27	Operating Temperature	-20° ~+85°	
28	Storage Temperature	-20° ~+85°	

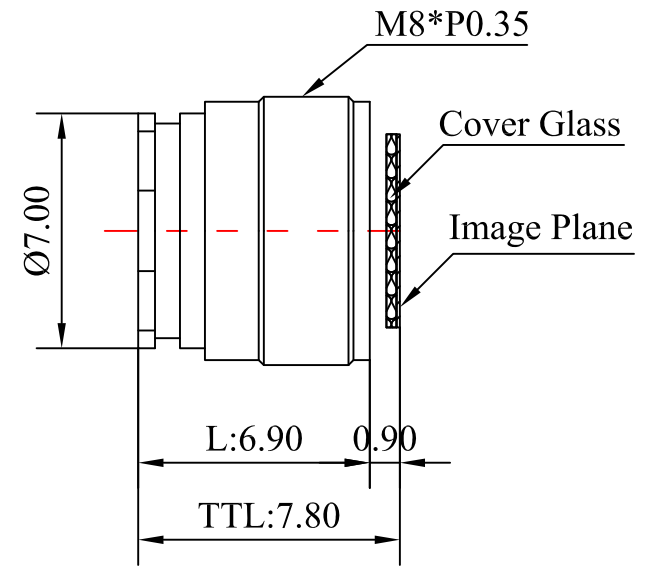
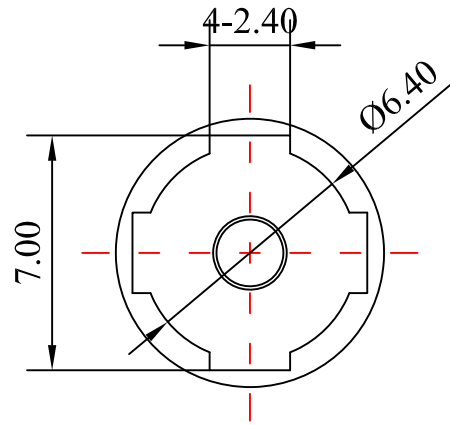
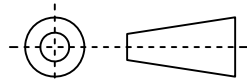

Scale	Remark	Tolerances	Date	Revised		福州创安光电科技有限公司 FUZHOU CHUANGAN OPTICS CO., LTD
7:1	X	±0.2	2019-06-17	CH3644AB Rev1.0		
Units	X.00	±0.10	Design	Linda	2019-06-17	 3D Angle Projection
	X.000	±0.001	Checked	Anna	2019-08-14	
mm	Angle	±0.5°	Approval	Sanmu	2019-08-21	