

1	Type	Pinhole Lens	
2	Resolution	MP	
3	Image Format	1/2.7"	
4	Image Circle	φ6.7mm(MAX)	
5	EFL	3.7mm	
6	TTL	10.39mm	
7	F/NO.	2.5	
8	FFL (M)	3.01mm	
9	BFL (O)	4.55mm	
10	For Sensor	1/2.7"	
11	F.O.V	Horizontal	90°
12		Vertical	70°
13		Diagonal	110°
14	TV Distortion	<-13%	
15	Relative Ill.	>55%	
16	Chief Ray Angle	<20°	
17	M.O.D	0.1m~∞	
18	Mount Type	M12*P0.5	
19	Dimension Figure	φ12*L7.38mm	
20	Lens Structure	2G2P	
21	IR-Filter	Non-IR	
22	Waterproof	No	
23	Weight	1.2g	
24	Iris Operation	Fixed	
25	Zoom Operation	Fixed	
26	Focus Operation	Manual	
27	Operating Temperature	-20° ~+85°	
28	Storage Temperature	-20° ~+85°	

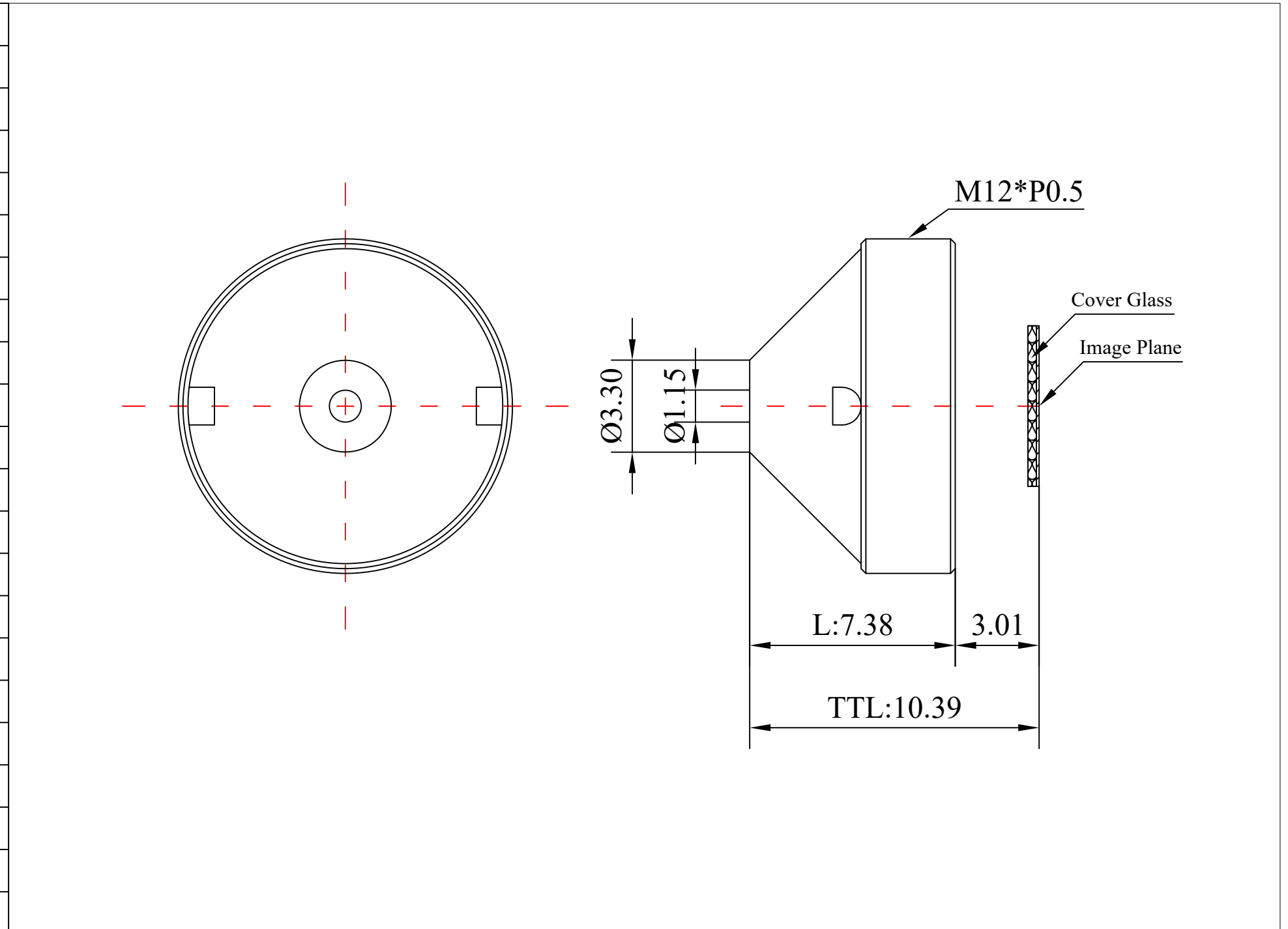
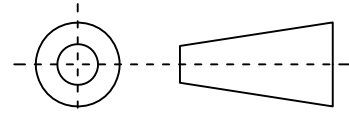

Scale	Remark	Tolerances	Date	Revised		福州创安光电科技有限公司 FUZHOU CHUANGAN OPTICS CO., LTD
6.5:1	X	±0.2	2020-03-18	CH3640A Rev1.0		
	X.0	±0.15				
Units	X.00	±0.10	Design	Linda	2019-05-19	 3D Angle Projection
	X.000	±0.001	Checked	Anna	2019-07-28	
mm	Angle	±0.5°	Approval	Sanmu	2019-08-30	