

1	Type	Wide Angle Lens	
2	Resolution	MP	
3	Image Format	1/3"	
4	Image Circle	φ6.0mm(MAX)	
5	EFL	1.8mm	
6	TTL	14.80mm	
7	F/NO.	2.4	
8	FFL (M)	3.5mm	
9	BFL (O)	3.7mm	
10	For Sensor	1/3"	
11	F.O.V	Horizontal	155°
12		Vertical	125°
13		Diagonal	190°
14	TV Distortion	<-80%	
15	Relative Ill.	>90%	
16	Chief Ray Angle	<22°	
17	M.O.D	0.1m~∞	
18	Mount Type	M12*P0.5	
19	Dimension Figure	φ14.0*L11.30mm	
20	Lens Structure	6G	
21	IR-Filter	T=50% & 650±10nm	
22	Waterproof	No	
23	Weight	---	
24	Iris Operation	Fixed	
25	Zoom Operation	Fixed	
26	Focus Operation	Manual	
27	Operating Temperature	-20° ~+85°	
28	Storage Temperature	-20° ~+85°	

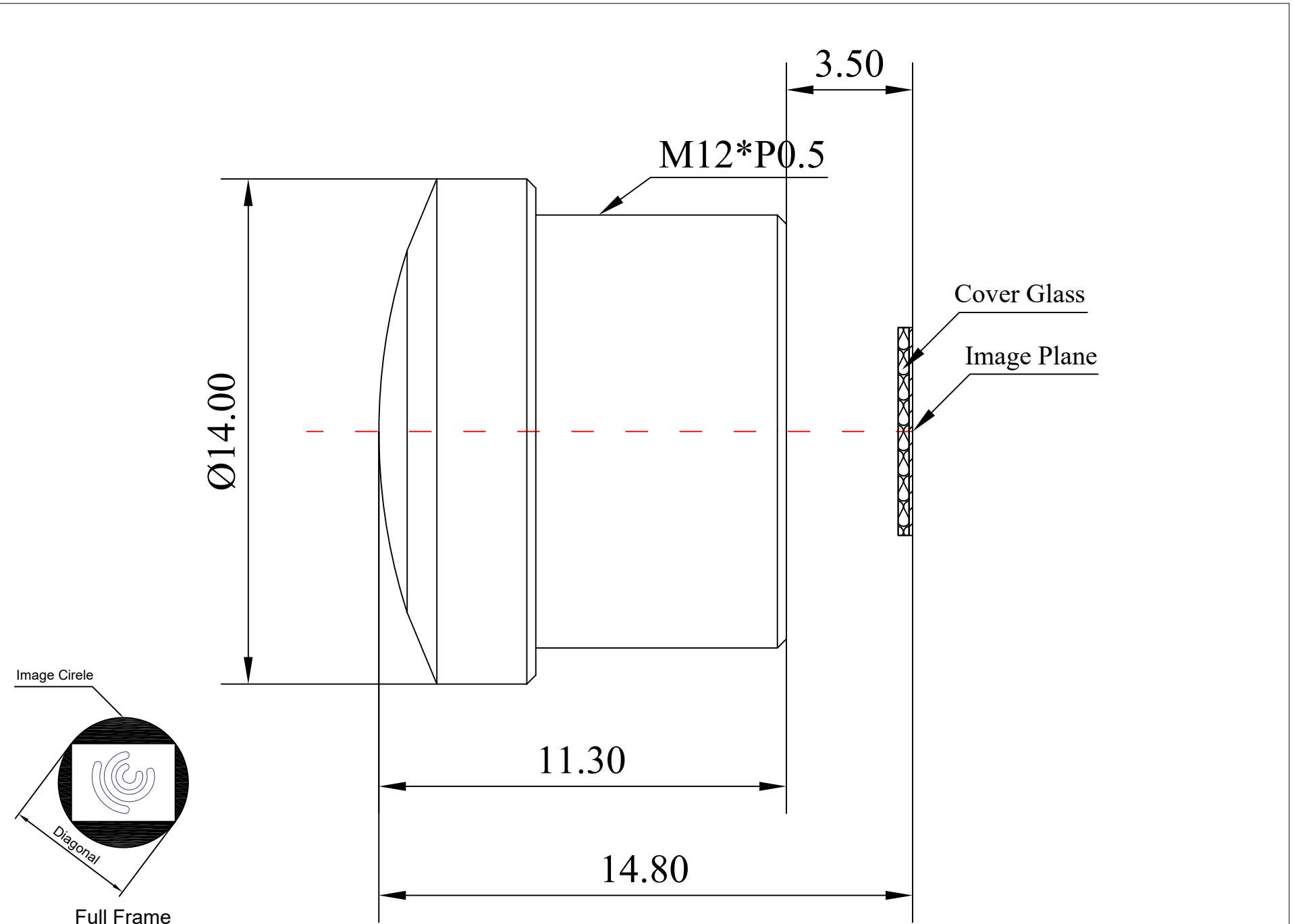

Scale	Remark	Tolerances	Date	Revised	
5:1	X	±0.2	2020-03-11	CH3635A Rev1.0	
	X.0	±0.15			
Units	X.00	±0.10	Design	Linda	2019-03-13
	X.000	±0.001	Checked	Anna	2019-06-26
mm	Angle	±0.5°	Approval	Sanmu	2019-06-29

福州创安光电科技有限公司
FUZHOU CHUANGAN OPTICS CO., LTD

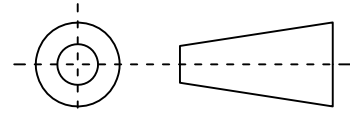

3D Angle Projection