

1	Type	Scan Lens	
2	Resolution	5MP	
3	Image Format	1/4"	
4	Image Circle	φ4.8mm(MAX)	
5	EFL	2.1mm	
6	TTL	17.60mm	
7	F/NO.	3.2	
8	FFL (M)	1.25mm	
9	BFL (O)	1.70mm	
10	For Sensor	1/4"	
11	F.O.V	Horizontal	83°
12		Vertical	58°
13		Diagonal	93.6°
14	TV Distortion	<-1.5%	
15	Relative Ill.	>61%	
16	Chief Ray Angle	<16.5°	
17	M.O.D	0.1m~∞	
18	Mount Type	M12*P0.5	
19	Dimension Figure	φ14.00*L16.35mm	
20	Lens Structure	2G2P Metal	
21	IR-Filter	T=50%&IR650±10nm	
22	Waterproof	No	
23	Weight	3.6g	
24	Iris Operation	Fixed	
25	Zoom Operation	Fixed	
26	Focus Operation	Manual	
27	Operating Temperature	-15° ~+65°	
28	Storage Temperature	-15° ~+65°	

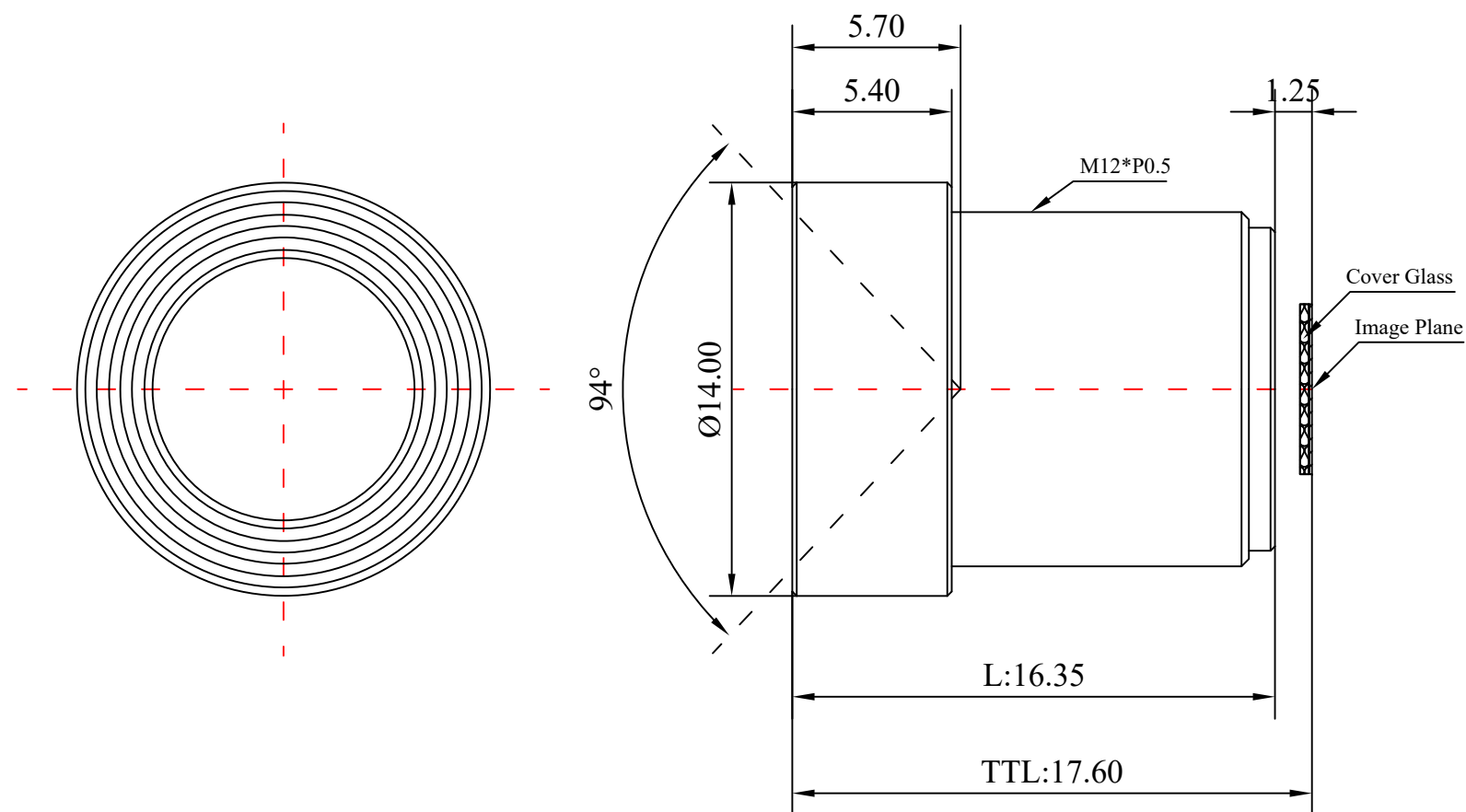

Scale	Remark	Tolerances	Date	Revised		福州创安光电科技有限公司 FUZHOU CHUANGAN OPTICS CO., LTD
5:1	X	±0.2	2019-10-22	CH3617A Rev1.0		
	X.0	±0.15				
Units	X.00	±0.10	Design	Linda	2019-07-21	
	X.000	±0.001	Checked	Anna	2019-08-29	
mm	Angle	±0.5°	Approval	Sanmu	2019-09-02	

