

1	Type	Wide Angle Lens	
2	Resolution	8MP	
3	Image Format	1/2.7"	
4	Image Circle	φ6.8mm(MAX)	
5	EFL	2.90mm	
6	TTL	21.94mm	
7	F/NO.	1.4	
8	FFL (M)	3.16mm	
9	BFL (O)	4.25mm	
10	For Sensor	1/2.7"	
11	F.O.V	Horizontal	117°
12		Vertical	62°
13		Diagonal	141°
14	TV Distortion	<-8.6%	
15	Relative Ill.	>55%	
16	Chief Ray Angle	<13.8°	
17	M.O.D	0.1m~∞	
18	Mount Type	M12*P0.5	
19	Dimension Figure	φ15.00*L18.78mm	
20	Lens Structure	7G	
21	IR-Filter	Non-IR	
22	Waterproof	IP67	
23	Weight	7.8g	
24	Iris Operation	Fixed	
25	Zoom Operation	Fixed	
26	Focus Operation	Manual	
27	Operating Temperature	-20° ~+85°	
28	Storage Temperature	-20° ~+85°	

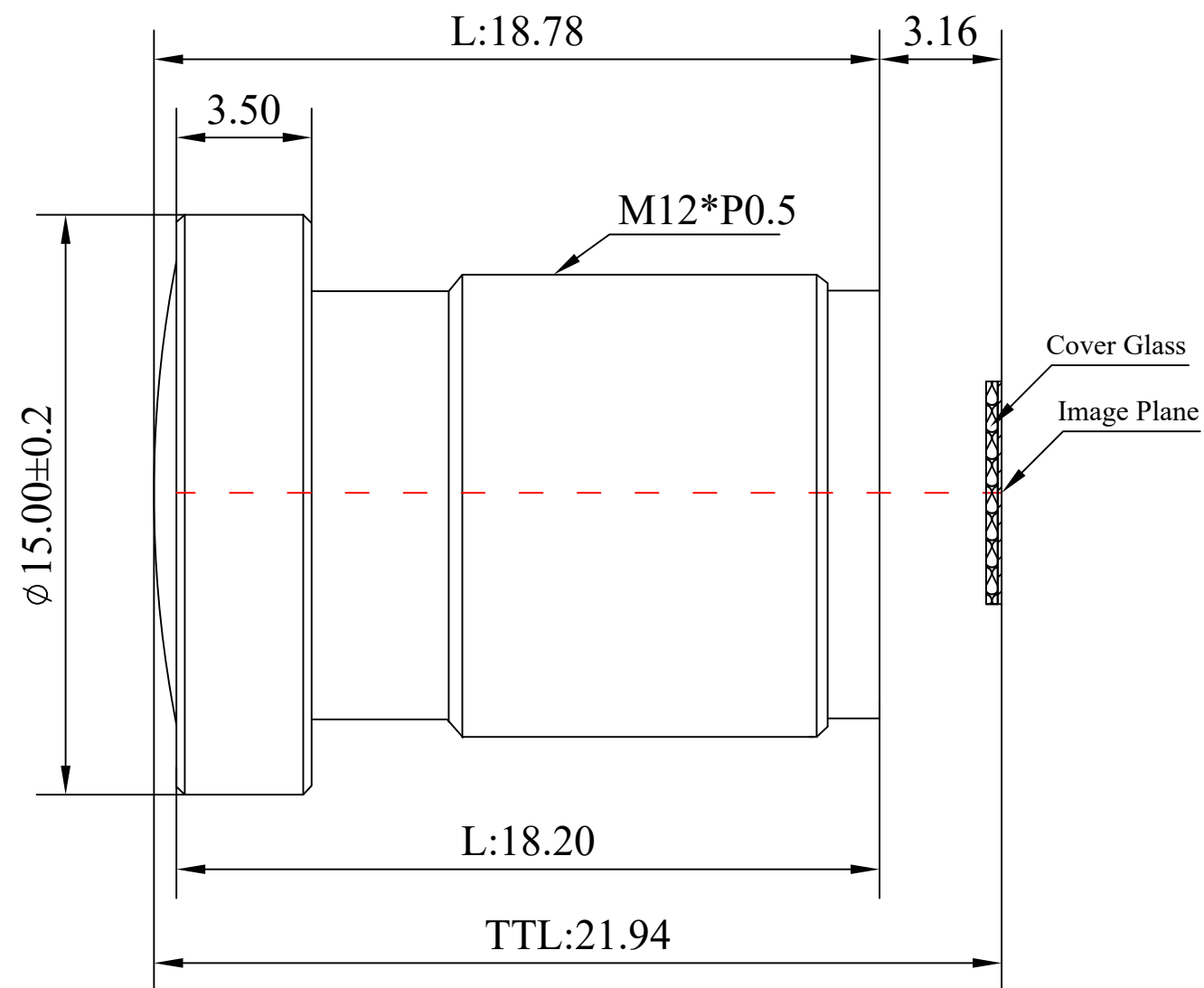

Scale	Remark	Tolerances	Date	Revised		福州创安光电科技有限公司 FUZHOU CHUANGAN OPTICS CO., LTD
4:1	X	±0.2	2019-08-16	CH3543A Rev1.0		
	X.0	±0.15				
Units	X.00	±0.10	Design	Linda	2018-03-12	
	X.000	±0.001	Checked	Anna	2018-05-28	
mm	Angle	±0.5°	Approval	Sanmu	2018-06-09	

