

1	Type	Machine Vision Lens
2	EFL	9mm
3	F.NO	F2.1~21
4	Resolution	MP
5	Image Format	2/3"
6	BFL (M)	13.53
7	BFL (O)	17.53
8	F.O.V (H*V)	52.5°*40.5°*63.5°
9		
10		
11	TV Distortion	<1%
12	M.O.D	0.2m~∞
13	Mount Type	C/CS
14	Dimension Figure	φ31.00*L37.67mm
15	Filter Size	No
16	Weight	120g

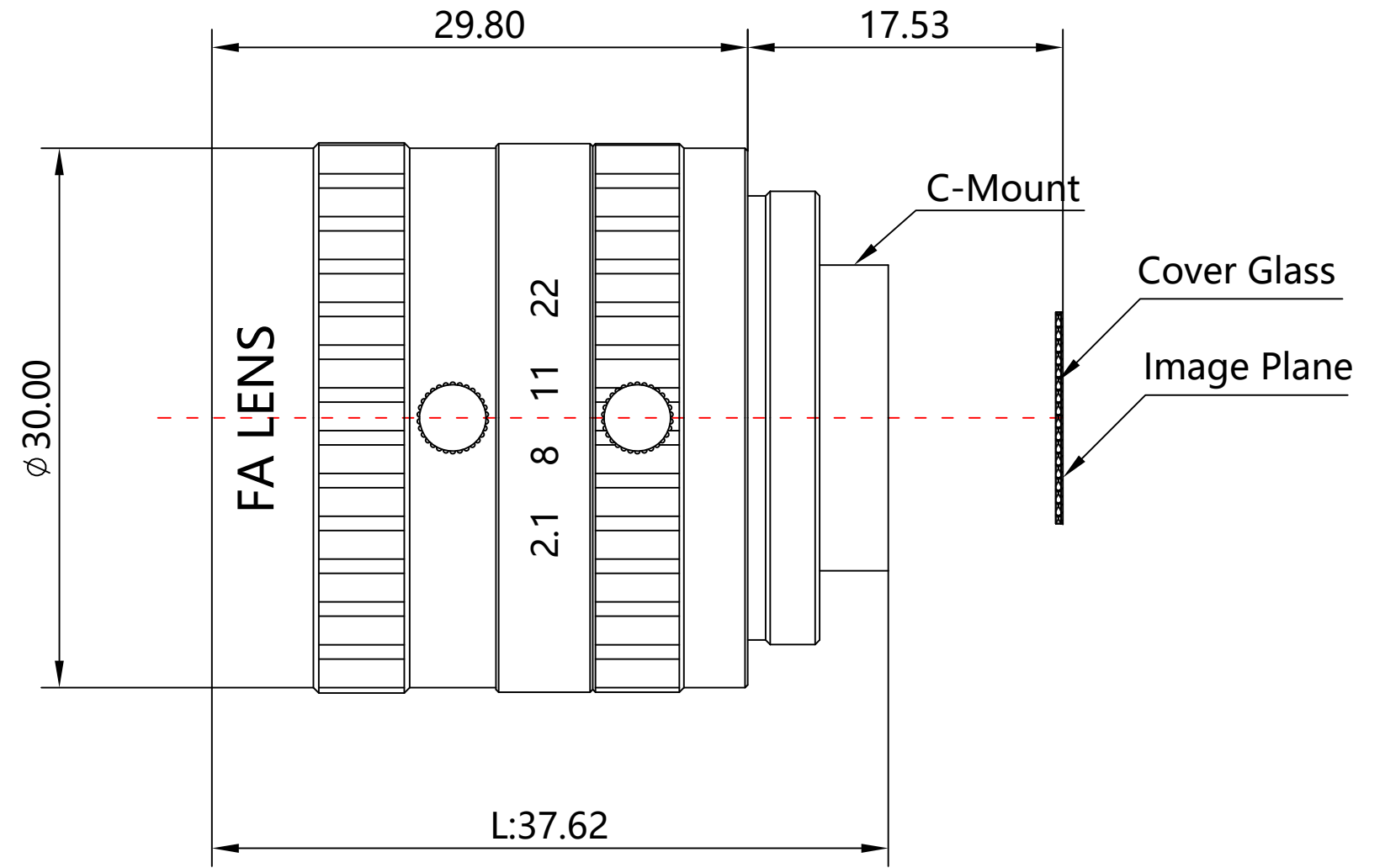

17	Iris Operation	Manual	Scale	Remark	Tolerances	Date	Revised		福州创安光电科技有限公司 FUZHOU CHUANGAN OPTICS CO., LTD
18	Zoom Operation	Fixed		2: 1	X	±0.2	2019-05-11	CH3516A Rev1.0	
19	Focus Operation	Manual	Units	X.0	±0.15	Design	Linda	2016-10-15	
20	Operating Temperature	-20° ~ +85°		X.000	±0.001	Checked	Anna	2016-10-20	
21	Storage Temperature	-20° ~ +85°	mm	Angle	±0.5°	Approval	Sanmu	2016-10-28	

