

1	Type	Wide Angle Lens			
2	Resolution	5MP			
3	Image Format	1/2.7"			
4	Image Circle	φ6.9mm(MAX)			
5	EFL	2.75mm			
6	TTL	14.86mm			
7	F/NO.	2.0			
8	FFL (M)	4.64mm			
9	BFL (O)	4.85mm			
10	For Sensor	AR0237	OV4689	AR0330	
11	F.O.V	Horizontal	135°	122°	110°
12		Vertical	70°	65°	61°
13		Diagonal	164°	147°	132°
14	TV Distortion	<-32%			
15	Relative Ill.	>50%			
16	Chief Ray Angle	<15°			
17	M.O.D	0.1m~∞			
18	Mount Type	M12*P0.5			
19	Dimension Figure	φ14.00*L10.22mm			
20	Lens Structure	6G			
21	IR-Filter	Non-IR			
22	Weight	3.5g			
23	Iris Operation	Fixed			
24	Zoom Operation	Fixed			
25	Focus Operation	Manual			
26	Operating Temperature	-20° ~+85°			
27	Storage Temperature	-20° ~+85°			

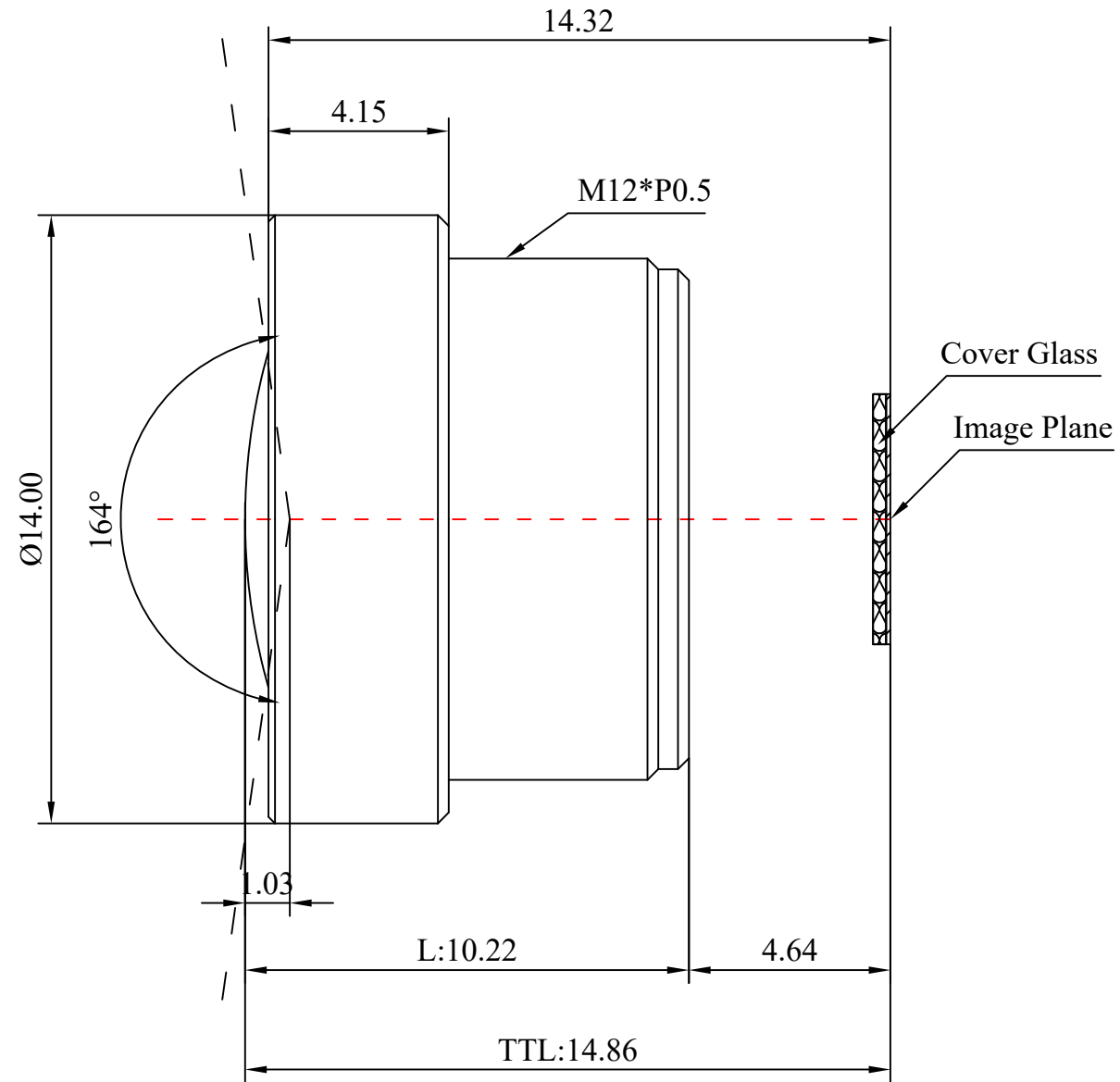
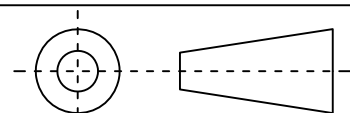

Scale	Remark	Tolerances	Date	Revised		福州创安光电科技有限公司 FUZHOU CHUANGAN OPTICS CO., LTD
5: 1	X	± 0.2	2019-07-16	CH348A Rev1.0		
	X.0	± 0.15				
Units	X.00	± 0.10	Design	Linda	2015-05-02	 3D Angle Projection
	X.000	± 0.001	Checked	Anna	2015-09-11	
mm	Angle	± 0.5°	Approval	Sanmu	2015-10-03	