

1	Type	Pinhole Lens	
2	Resolution	MP	
3	Image Format	1/2.5"	
4	Image Circle	φ7.2mm	
5	EFL	2.8mm	
6	TTL	80.53mm	
7	F/NO.	F1.8	
8	FFL (M)	7.53mm	
9	BFL (O)	12.53mm	
10	For Sensor	1/2.5"	
11	F.O.V	Horizontal	78°
12		Vertical	56°
13		Diagonal	90°
14	M.O.D	0.1m~∞	
15	Mount Type	CS-Mount	
16	Dimension Figure	φ33.00*L73.0mm	
17	Lens Structure	13G	
18	IR-Filter	Non-IR	
19	Waterproof	No	
20	Weight	68.5g	
21	Iris Operation	Manual	
22	Zoom Operation	Fixed	
23	Focus Operation	Manual	
24	Operating Temperature	-20° ~+85°	
25	Storage Temperature	-20° ~+85°	

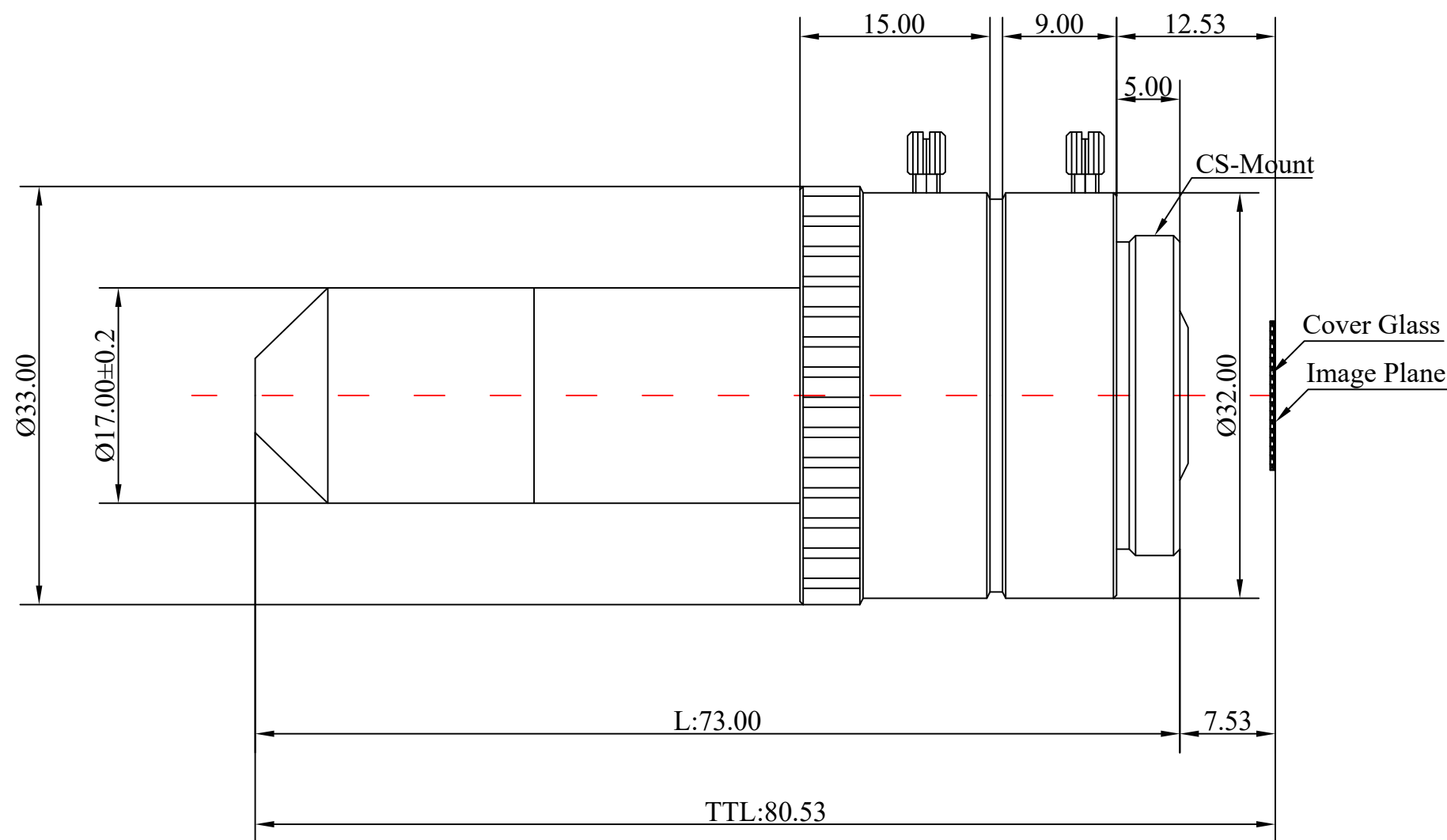

Scale	Remark	Tolerances	Date	Revised		福州创安光电科技有限公司 FUZHOU CHUANGAN OPTICS CO., LTD
4:1	X	±0.2	2022-11-25	CH3324A Rev1.0		
	X.0	±0.15				
Units	X.00	±0.10	Design	Linda	2022-08-01	
	X.000	±0.001	Checked	Anna	2022-09-09	
mm	Angle	±0.5°	Approval	Sanmu	2022-09-10	

