

1	Type	Fisheye Lens		
2	Resolution	8MP		
3	Image Format	1/2.3"		
4	Image Circle	φ4.3mm(MAX)		
5	EFL	1.19mm		
6	TTL	28.00mm		
7	F/NO.	2.0		
8	FFL (M)	3.0mm		
9	BFL (O)	3.11mm		
10	For Sensor	Ø4.3mm	Ø4.0mm	
11	F.O.V	Horizontal	214°	188°
12		Vertical	214°	188°
13		Diagonal	214°	188°
14	OPT Distortion	<-97.5%		
15	Relative Ill.	>87%		
16	Chief Ray Angle	<10°		
17	M.O.D	0.1m~∞		
18	Mount Type	M12*P0.5		
19	Dimension Figure	φ29.0*L25.0mm		
20	Lens Structure	10G		
21	IR-Filter	Non-IR		
22	Waterproof	No		
23	Weight	---		
24	Iris Operation	Fixed		
25	Zoom Operation	Fixed		
26	Focus Operation	Manual		
27	Operating Temperature	-20° ~+85°		
28	Storage Temperature	-20° ~+85°		

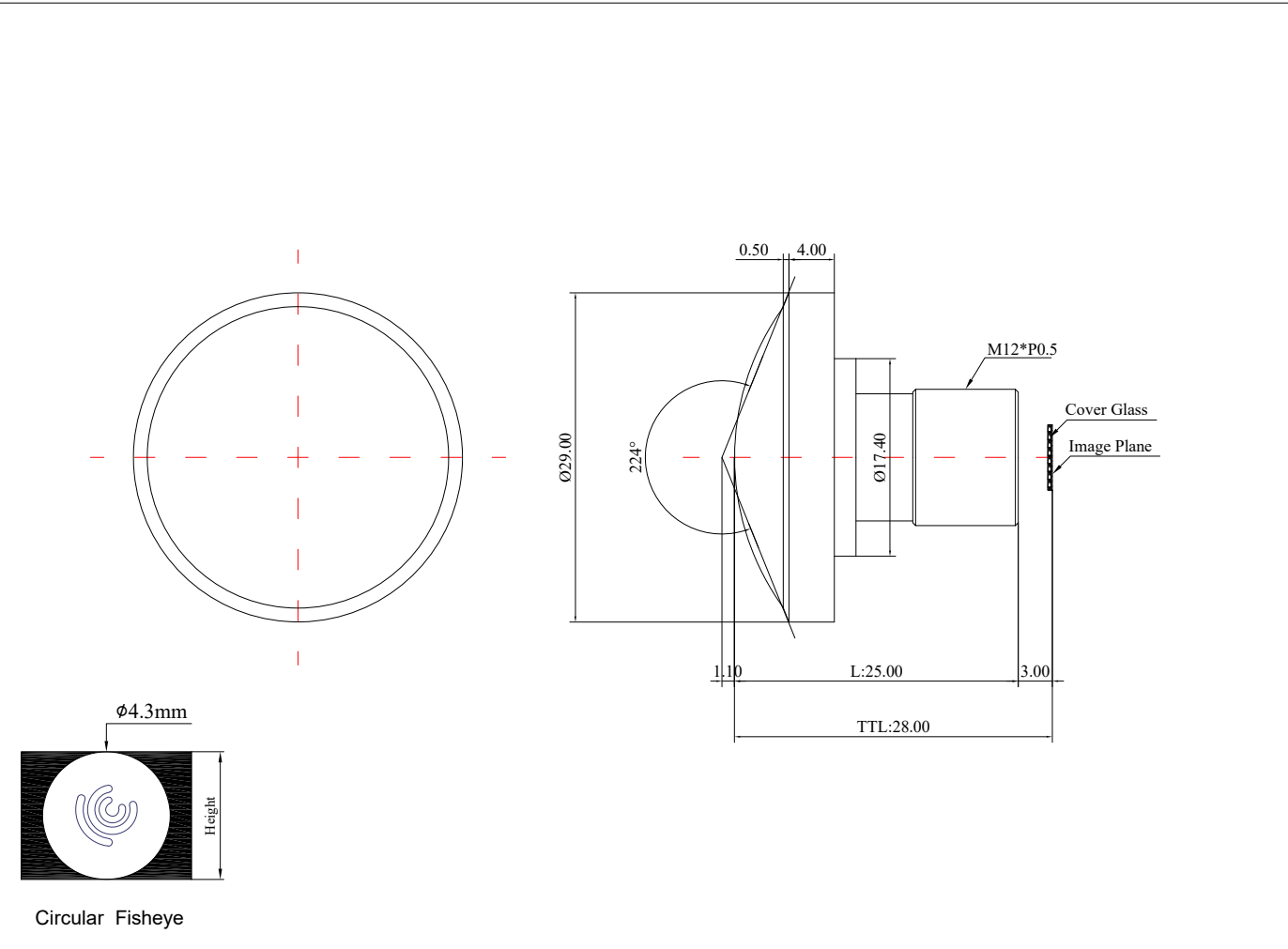

Scale	Remark	Tolerances	Date	Revised	
4:1	X	±0.2	2023-04-25	CH327D Rev1.3	
Units	X.00	±0.10	Design	Linda	2019-08-03
	X.000	±0.001	Checked	Anna	2019-08-13
mm	Angle	±0.5°	Approval	Sanmu	2019-09-20

福州创安光电科技有限公司  
 FUZHOU CHUANGAN OPTICS CO., LTD

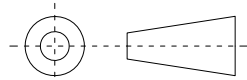

3D Angle Projection