

1	Type	Fisheye Lens	
2	Resolution	10MP	
3	Image Format	1/2.3"&1/2.5"	
4	Image Circle	φ4.4mm(V-MAX)	
5	EFL	1.35mm	
6	TTL	32.85mm	
7	F/NO.	2.0	
8	FFL (M)	3.03mm	
9	BFL (O)	3.23mm	
10	F-Theta Distortion	<-0.6%	
11	F.O.V	Horizontal	180°
12		Vertical	180°
13		Diagonal	180°
14	TV Distortion	<-50%	
15	Relative Ill.	>80%	
16	Chief Ray Angle	<18°	
17	M.O.D	0.1m~∞	
18	Mount Type	M12*P0.5	
19	Dimension Figure	φ34.00*L29.82mm	
20	Lens Structure	9G	
21	IR-Filter	T=50% & 650±10nm	
22	Waterproof	No	
23	Weight	23.3g	
24	Iris Operation	Fixed	
25	Zoom Operation	Fixed	
26	Focus Operation	Manual	
27	Operating Temperature	-20° ~+85°	
28	Storage Temperature	-20° ~+85°	

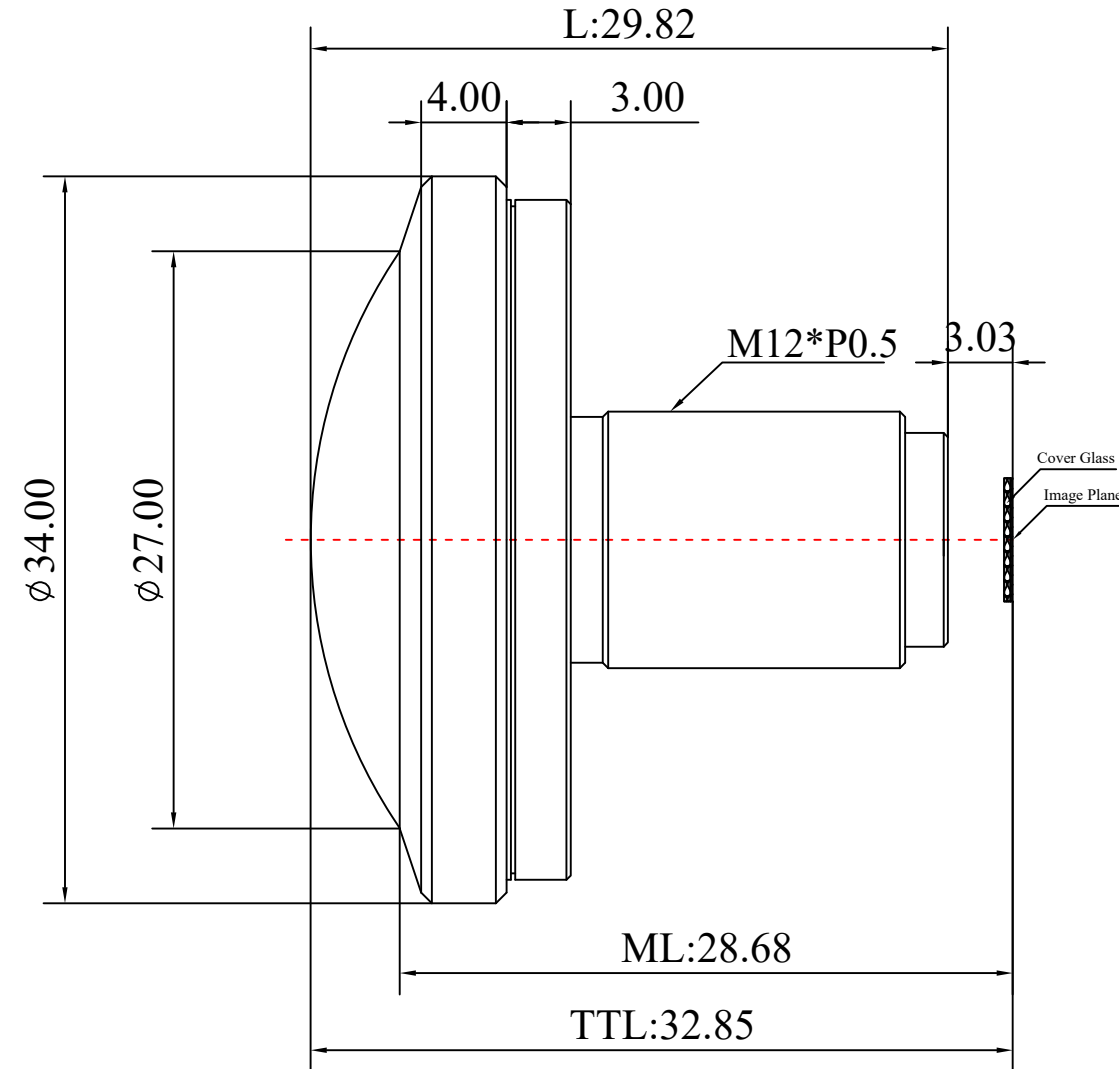
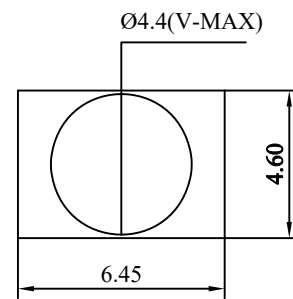
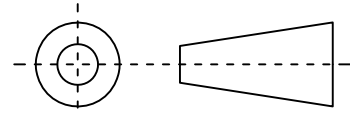

Scale	Remark	Tolerances	Date	Revised		福州创安光电科技有限公司 FUZHOU CHUANGAN OPTICS CO., LTD
4:1	X	±0.2	2019-07-22	CH315A Rev1.0		
	X.0	±0.15				
Units	X.00	±0.10	Design	Linda	2016-10-17	 3D Angle Projection
	X.000	±0.001	Checked	Anna	2016-12-05	
mm	Angle	±0.5°	Approval	Sanmu	2016-12-10	