

1	Type	Wide Angle Lens		
2	Resolution	MP		
3	Image Format	1/2.7"		
4	Image Circle	φ6.75mm(MAX)		
5	EFL	2.8mm		
6	TTL	21.97mm		
7	F/NO.	2.0		
8	FFL (M)	4.16mm		
9	BFL (O)	5.65mm		
10	For Sensor	OV2710	AR0330	
11	F.O.V	Horizontal	113°	96.6°
12		Vertical	58°	60.5°
13		Diagonal	137°	121.3°
14	TV Distortion	<-12%(H)	<-11%(H)	
15	Relative Ill.	>45%	>50%	
16	Chief Ray Angle	<9.7°	<9°	
17	M.O.D	0.1m~∞		
18	Mount Type	M12*P0.5		
19	Dimension Figure	φ14.0*L17.81mm		
20	Lens Structure	4G		
21	IR-Filter	T=50% & 650±10nm		
22	Waterproof	No		
23	Weight	7.1g		
24	Iris Operation	Fixed		
25	Zoom Operation	Fixed		
26	Focus Operation	Manual		
27	Operating Temperature	-20° ~+85°		
28	Storage Temperature	-20° ~+85°		

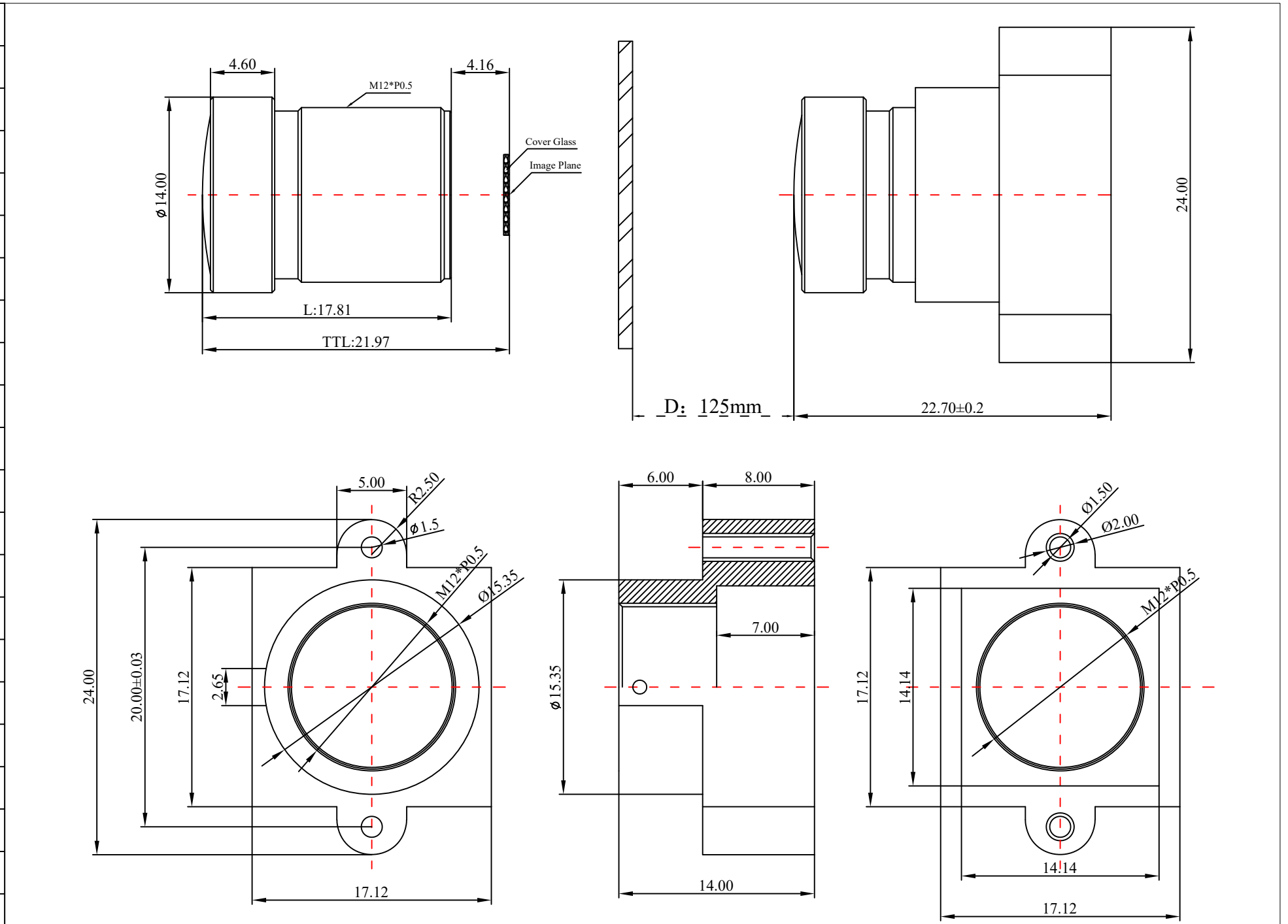
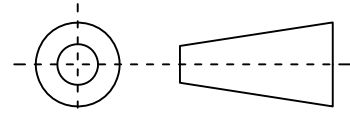

Scale	Remark	Tolerances	Date	Revised		福州创安光电科技有限公司 FUZHOU CHUANGAN OPTICS CO., LTD
4:1	X	±0.2	2019-04-26	CH231A Rev1.0		
	X.0	±0.15				
Units	X.00	±0.10	Design	Linda	2019-05-26	 3D Angle Projection
	X.000	±0.001	Checked	Anna	2019-07-20	
mm	Angle	±0.5°	Approval	Sanmu	2019-07-20	