

1	Type	Wide Angle Lens	
2	Resolution	5MP	
3	Image Format	1/4"	
4	Image Circle	φ4.8mm(MAX)	
5	EFL	2.0mm	
6	TTL	13.06mm	
7	F/NO.	2.4	
8	FFL (M)	2.38mm	
9	BFL (O)	4.01mm	
10	For Sensor	1/4"	
11	F.O.V	Horizontal	115°
12		Vertical	87°
13		Diagonal	170°
14	TV Distortion	<-20%	
15	Relative Ill.	>80%	
16	Chief Ray Angle	<9°	
17	M.O.D	0.1m~∞	
18	Mount Type	M8*P0.5	
19	Dimension Figure	φ12.00*L10.68mm	
20	Lens Structure	5G	
21	IR-Filter	T=50% & 650±10nm	
22	Waterproof	No	
23	Weight	3.5g	
24	Iris Operation	Fixed	
25	Zoom Operation	Fixed	
26	Focus Operation	Manual	
27	Operating Temperature	-20° ~+85°	
28	Storage Temperature	-20° ~+85°	

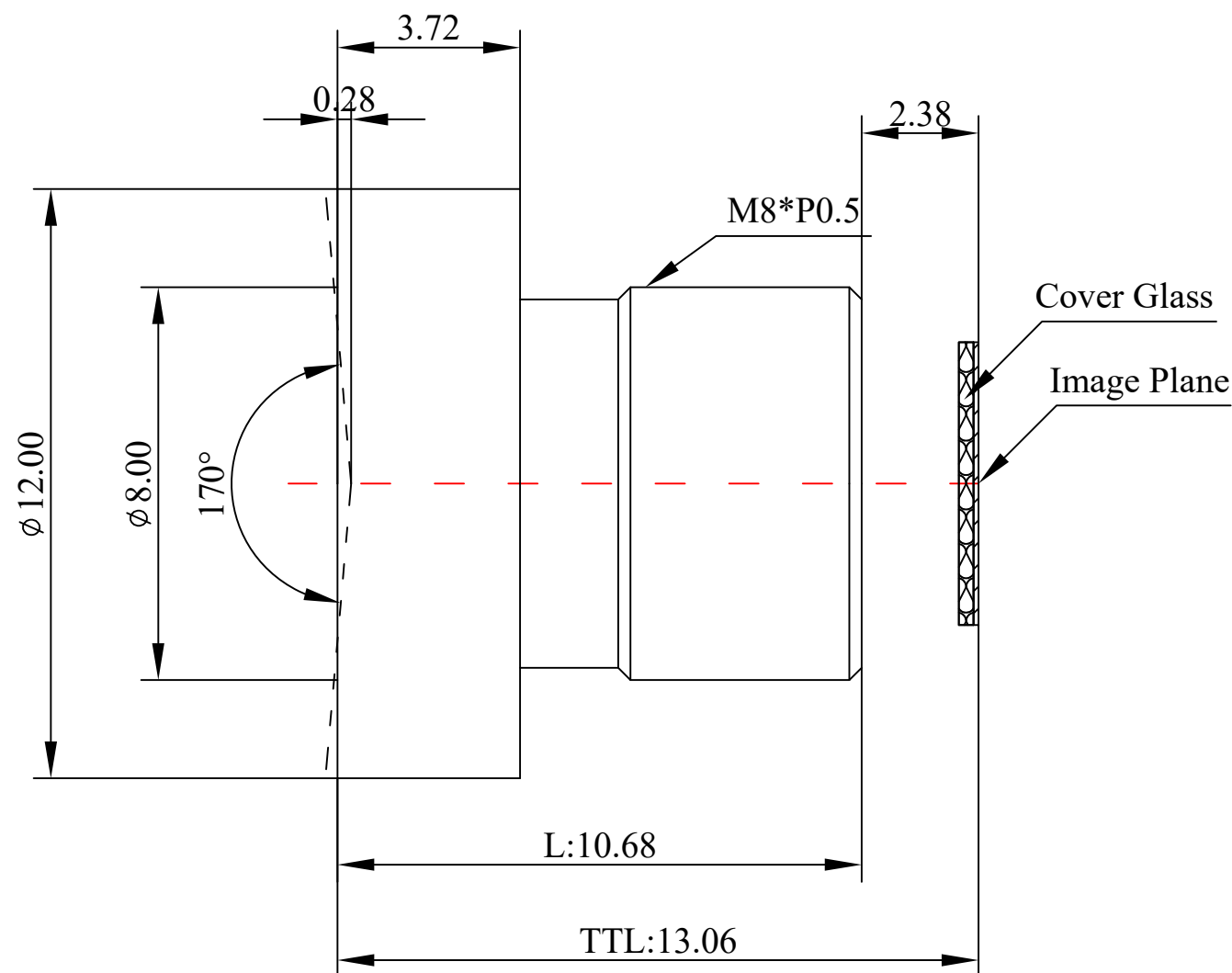
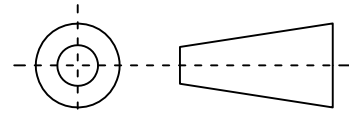

Scale	Remark	Tolerances	Date	Revised		福州创安光电科技有限公司 FUZHOU CHUANGAN OPTICS CO., LTD
5 : 1	X	±0.2	2023-05-18	CH1308AB Rev1.2		
	X.0	±0.15				
Units	X.00	±0.10	Design	Linda	2016-03-08	 3D Angle Projection
	X.000	±0.001	Checked	Anna	2016-05-17	
mm	Angle	±0.5°	Approval	Sanmu	2016-05-19	